

waukesha®



2ND GENERATION

Auto Recharging Dehydrating Breather Manual

ARDB2-MANUAL – 2.11

Read and understand this manual prior to operating or servicing the products.



CONTENTS

General Description	3-4
Operational Diagram (Standard ARDB2)	5
Safety Warnings & Cautions	6
Specifications	7
Standard vs. Arctic ARDB2 Operation below 0°C	8
Standard Installation	9-10
Electrical Installation	11
Unit Start-Up & DIP Switch Settings	12
Unit Alarms & Troubleshooting	13
Periodic Inspection & Maintenance	14
Appendix A: Humidity Sensor Service (Blinking Amber)	15–20
Appendix B: Obstructed Air Path or Vacuum Sensor Failure (Blinking Red)	21
Appendix C: Flange Mount Installation	22–23
Appendix D: Adapter ARDB2 to ARDB Mounting	24–26
Appendix E: Optional Conduit Box Adapter Wiring	27-29
Contact Information	29
Blank Page	30



GENERAL DESCRIPTION

The second generation Waukesha® Auto Regenerating Dehydrating Breather Systems (ARDB2) have been designed to remove moisture from the air of load tap changer tanks, conservators or other sealed tanks. Heaters controlled by an adjustable timer and humidity sensor provide automatic recharging of the silica gel desiccant, eliminating the need for manual intervention. Logic controls ensure that regeneration occurs only during transformer exhale, effectively “learning” the best time of day to run. Systems can be configured for various tank (air volume) sizes:

- Small Breather – Designed for 8,000 gallons (30,283 liters) or less
- Large Breather – Designed for 18,000 gallons (68,137 liters) or less

Any combination of breathers can be configured for larger volumes. Each breather includes the logic circuits that will operate the breather independently.

GENERAL DESCRIPTION *(continued)*

System Principal of Operation

See Figure 1A on page 5. During normal operation, air enters the breather through slots in the upper molding and passes through the desiccant to the center of the assembly. The center tube contains several holes along the entire length, forcing the airflow to disperse through the maximum surface area of desiccant. Airflow then travels through the center tube, along a horizontal path to the isolation solenoid and humidity sensor, and eventually through the top port.

During regeneration, temperature regulating heater elements within the center tube are energized to heat the desiccant to a specified temperature. Any moisture present in the desiccant is driven outward to the polycarbonate tube where it turns into condensate. It runs to the bottom of the breather assembly where it is discharged through the water drain filter. **NOTE: The white plastic float ball was eliminated effective June 2010.** Also during regeneration, the solenoid valve at the top of the breather assembly directs exhaled air from the tank to a side port open to atmosphere. If the tank attempts to inhale during regeneration, logic controls suspend regeneration mode and direct the tank to breathe through the desiccant.

Construction

ARDB2 systems are shipped as a single integrated assembly along with accessories necessary to install. Both sizes of breathers are very similar and are constructed with a molded integrated top and controls housing, a lower molded housing, integrated heating elements, heat conductive fins, screen, condenser media and filter vent system. Watertight over-molded power and customer monitoring harnesses eliminate the need for electrical conduit directly tied to the breather.

The housings are molded from a high strength, high temperature & UV-stabilized plastic. The outer polycarbonate tube is high strength, UV-stabilized and transparent to allow easy visual indication of the desiccant condition. Sealed lenses on the control cover protect LED lamps that provide easy visual indication of breather status.

Intelligent Controls

ARDB2 systems feature an integrated PCB microcontroller that constantly monitors the condition of airflow through the breather. User adjustable, time-based controls regenerate the desiccant regardless of condition. Humidity sensing capability automatically overrides and regenerates the desiccant, if needed, between the set timer frequencies. Constant monitoring of airflow direction allows the logic circuit to automatically adjust timer controls to “learn” the best time of day to regenerate.

Internal diagnostics constantly monitor, evaluate and adjust the performance of the components to ensure breather operation will always provide optimum protection for the airspace. All controls and components default to a standard desiccant breather in the event of power loss.

The ARDB2 systems include an alarm relay, —which may be remotely monitored—, that monitors the heating and solenoid function, vacuum switch health and line power.

NOTE: Units manufactured prior to 6/30/2010 have only “Heater ON” monitor relay.

⚠ CAUTION Once desiccant (gel beads) has been added to the unit it **MUST** be kept in a **VERTICAL POSITION**.

⚠ CAUTION Transformer/LTC port **MUST** be **SEALED** before adding desiccant (gel beads).

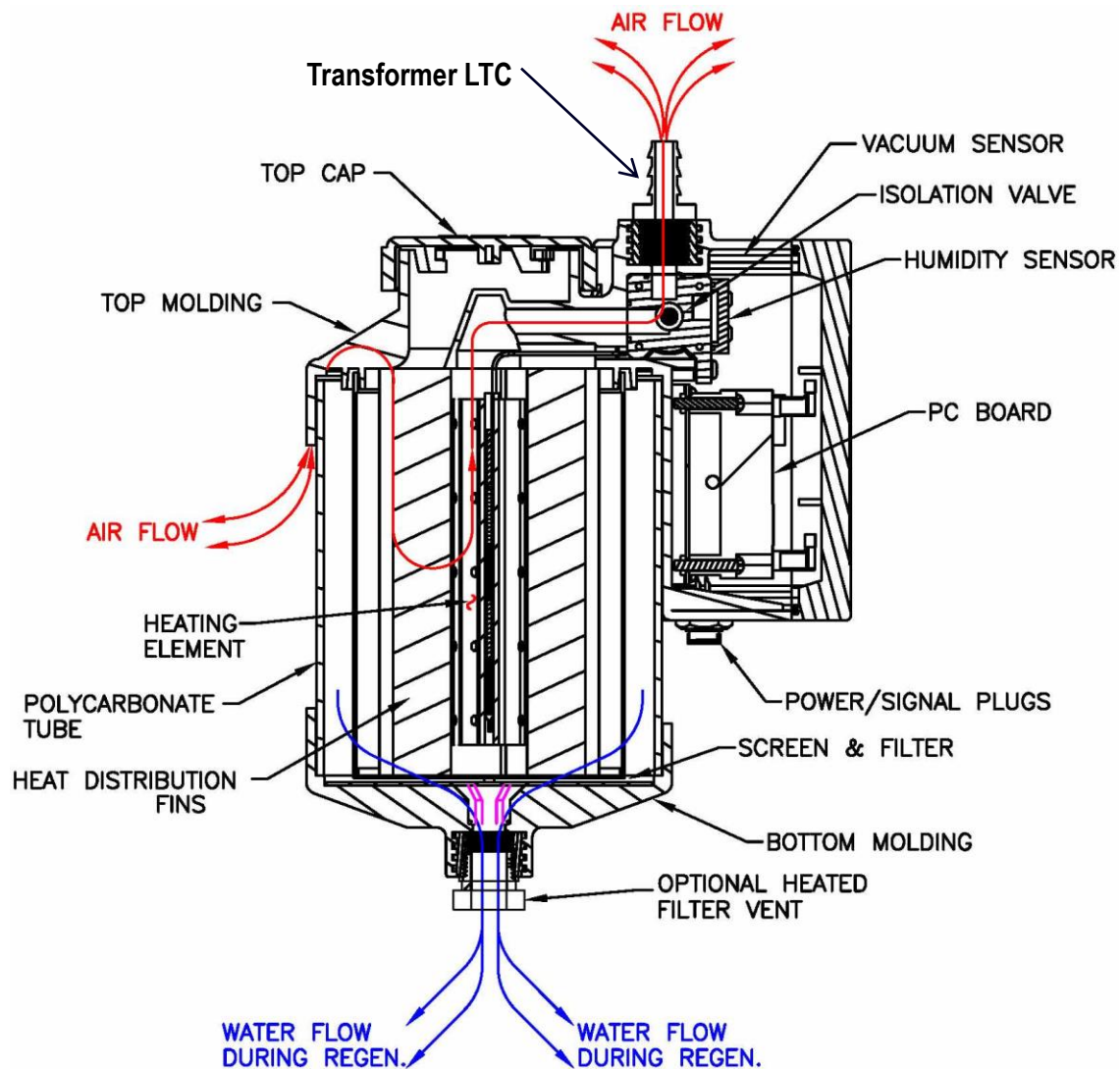

Figure 1A – Standard ARBD2 Functional Operation and Component Identification

NOTE: The white plastic float ball was eliminated effective June 2010.

SAFETY INFORMATION

Correct use of this equipment is important for your personal safety and for trouble-free functioning of the unit. Incorrect control or attempts to perform adjustments could cause damage or lead to incorrect operation. Be sure to read and understand all instructions before attempting to operate the unit. The unit is designed to produce dry air. Do not operate the unit beyond its limits (see specifications on page 7). In addition to the warnings and cautions in this manual, use the following safety guidelines for safe operation of the unit.

- ⚠ WARNING** This unit is an electrical appliance. Make sure that the main power supply is disconnected before you perform installation, maintenance or repair work.
- ⚠ WARNING** If you must work on the equipment with the main power supply on, be aware of electrical hazards.
- ⚠ WARNING** The heaters and globe become very hot when operating. Be careful when you touch the system if the amber light is on (heater energized).
- ⚠ CAUTION** Do not block the ventilation inlets and outlets, this could cause damage to the unit.
- ⚠ WARNING** In order to prevent injury or damage caused by the sudden release of compressed air, make sure that the unit and connected systems are fully depressurized before you start uncoupling parts of the system.

IMPORTANT: The following words and symbols appear throughout this manual and designate important safety instructions:

- ⚠ DANGER** Indicates information important to the proper operation of the equipment. Failure to observe will result in damage to the equipment and/or severe bodily injury or death.
- ⚠ WARNING** Indicates information important to the proper operation of the equipment. Failure to observe may result in damage to the equipment and/or severe bodily injury or death.
- ⚠ CAUTION** Indicates information important to the proper operation of the equipment. Failure to observe may result in damage to the equipment.

Read all safety instructions to avoid personal injury or death & to avoid damage to the unit or property.

SPECIFICATIONS

COMPONENTS		ELECTRICAL	
Airflow Solenoid	12VDC non-latching	Voltage/Frequency	100–240VAC, 50/60Hz
Humidity Sensor	RH 2% to 100%	Power Consumption*	0 – 5.5A
Vacuum Switch	Normally open, 0.1 psi vacuum to close	Alarm Relay**	Normally CLOSED. Held OPEN with power — 4A 120 VAC, 4A 30 VDC
Indicator Lights	LED	Inrush Damping	Staged heating 30 seconds apart (2KG Unit Only)
Timer Control	Dip switch on PCB		
OPERATION		AMBIENT CONDITIONS	
Time Base Settings	5, 10, 20, 40 day settings	Temperature: Standard ARDB2	Range 0° to 80°C
Relative Humidity Sense Trigger	50% required to activate regeneration	Temperature: Arctic Zone ARDB2	Range –50° to 80°C
Heating	10 seconds staging, 3 hour full power	Air quality	Normally clean ambient air
Cooling Time	10 minutes before solenoid deactivation	Relative Humidity	>90%
Vacuum Detection	10 seconds continuous required	ENVIRONMENT	
Failure Detection	Heater, vacuum switch, humidity sensor	Location	Indoor/Outdoors, wall-mounted

* Typical operation is non-regenerating: 20mA small Breather — 5.5A inrush, 1 to 1.5A nom Large Breather — 5.5A inrush, 2 to 3A nom

** Units manufactured prior to 6/30/2010 have only “Heater ON” monitored relay rated at 1A 120VAC/30VDC

Table 1 – Auto Recharging Dehydrating Breather Specifications

OPERATIONAL DIFFERENCES BETWEEN THE STANDARD ARDB2 AND THE COLD WEATHER ARDB2

Standard ARDB2

- Fully functional between 0°C and 80°C
- Below 0°C operation:
 - Still **FULLY** functional as a regenerating dry air breather, except, in lower temperatures, water from the automatic regeneration process will freeze in the filter vent.
 - Some light frost may form on the inside of the polycarbonate tube but will in no way affect the operation of the ARDB2 auto-recharging breather.
 - Does not impact the unit's ability to continue to reliably provide dry air to the protected space — As the temperature rises above 0°C, any frozen water in the filter vent and/or frost will quickly melt, clearing the filter vent.

NOTE: At temperatures below 0°C, the air only contains a minimum amount of moisture content, which should minimize the occurrence of the non-heated filter vent freezing.

Arctic ARDB2

- Fully functional between –50°C and 80°C.
- Below 0°C operation:
 - From 0°C to –50°C, the heated filter vent prevents freezing of the water generated from the regeneration process, allowing complete drainage.
 - Some light frost may form on the inside of the polycarbonate tube but will in no way affect the operation of the Arctic ARDB2 auto-recharging breather.
 - Below –50°C, water from the automatic regeneration process may begin to freeze in the heated filter vent. This will in no way effect the operation of the Arctic ARDB2 in servicing the protected space.

NOTE: At temperatures below –50°C, the air only contains an absolute minimum amount of moisture content, which should minimize the occurrence of the heated filter vent freezing.

INSTALLATION *(using included hose and hose barbs)*

⚠ CAUTION The unit must be mounted in an upright position. Do not mount the unit on its side or back.

- ⚠ CAUTION** Do not block the ventilation inlets and outlets as this could cause damage to the unit and provide inadequate protection for the airspace.
- The unit must be mounted level and upright.
 - All piping & fittings **MUST** be non-corrosive (polymer, brass, copper, stainless steel or equivalent)
 - The unit and piping must be installed so that oil cannot enter the breather.
 - Install unit away from heat sources.
 - Do not install in an enclosed cabinet; proper ventilation is required.

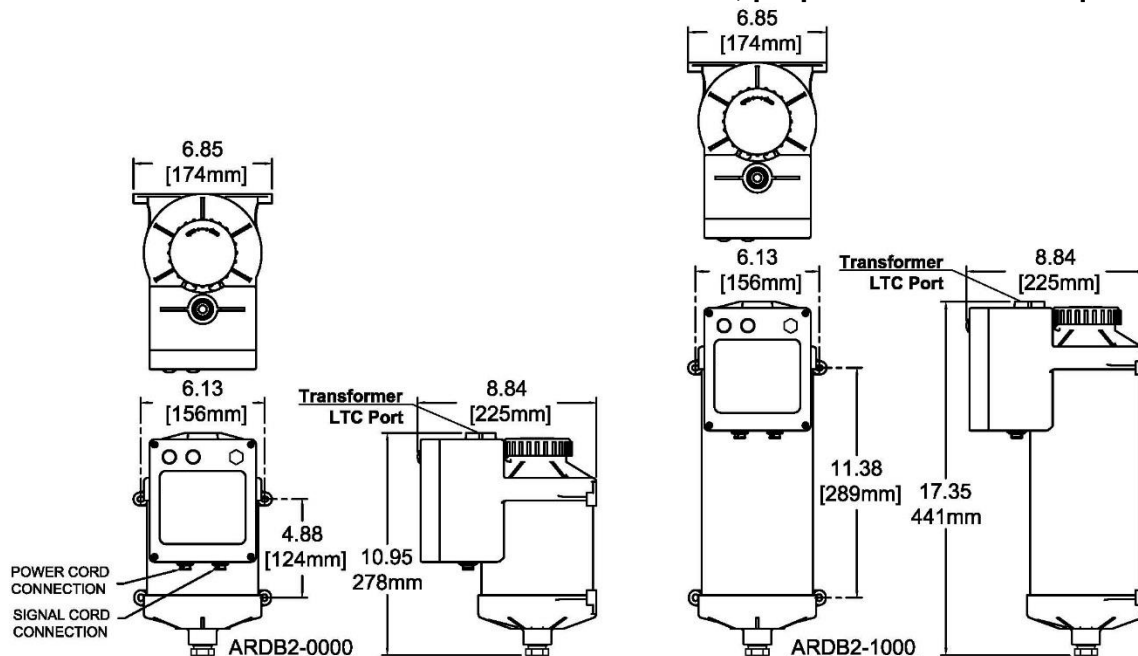

Figure 2 – ARDB2 Mounting Dimensions

1. Measure and mark the mounting holes or studs as shown by the center-to-center distances in Figure 2 above.
2. Place the unit into position and install with 1/4" hardware into top of breather casting (not included).
3. Install included hose barb securely (see Figure 3 on page 10). Use of thread sealant (if hose barb is not already pre-Teflon taped) is required to prevent water from flooding the humidity sensing chamber.

— **INSTALLATION INSTRUCTIONS CONTINUED ON NEXT PAGE** —

INSTALLATION (continued)

CAUTION The connection to tank port is critical to ensure that no oil can enter the breather.

CAUTION The piping between the unit and the tank **MUST** be free of oil residue and debris.

CAUTION The Transformer/LTC port **MUST** be **SEALED** before installing desiccant (gel beads). **KEEP** the unit **VERTICAL** once the gel beads have been added.

Transformer LTC

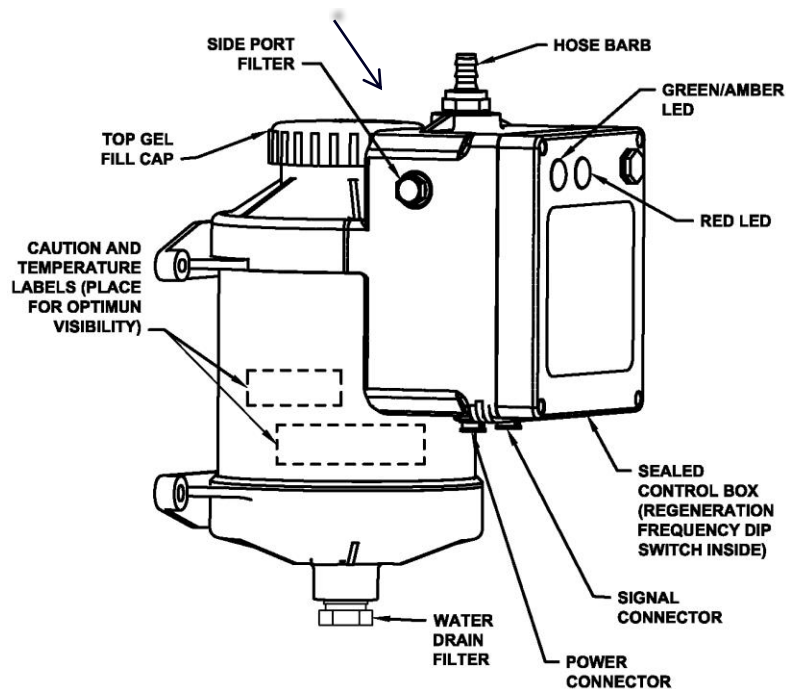

Figure 3 – ARDB2 Fittings and Label Installation

1. Install included hose barb to tank piping or port. Use of thread sealant is required to prevent leaks.
2. Install included hose between hose barbs. **The top port and side port on the breather MUST be sealed before installing the desiccant.**
3. Remove top cap and pour silica gel (included) into breather. Small breather requires 2.2lbs/1kg of desiccant and large breather requires 4.4lbs/2kg of desiccant. Replace cap and ensure it is locked in place.
4. Install side port filters (use pipe sealant if filter is not pre-Teflon taped) and water drain filter (see Figure 3 above).
5. Install temperature and caution labels. Locate these labels on the globe in the areas best visible to service personnel (depending upon mounting location).

ELECTRICAL CONNECTIONS

⚠ WARNING Electrical shock hazard. Failure to follow these instructions could result in serious injury or death.

- Electrical ground is required on this appliance.
- Do not use an extension cord with this appliance.
- The unit should be grounded according to local electrical codes to prevent the possibility of electrical shock. It requires a grounded receptacle with separate electrical lines, protected by fuses or circuit breaker of the proper rating.
- Check with a qualified electrician if you are in doubt as to whether the appliance is properly grounded.

⚠ WARNING Connecting any power to the **GREEN, RED** and/or **WHITE** wires of the 5-wire harness will **PERMANENTLY DESTROY** breather operation.

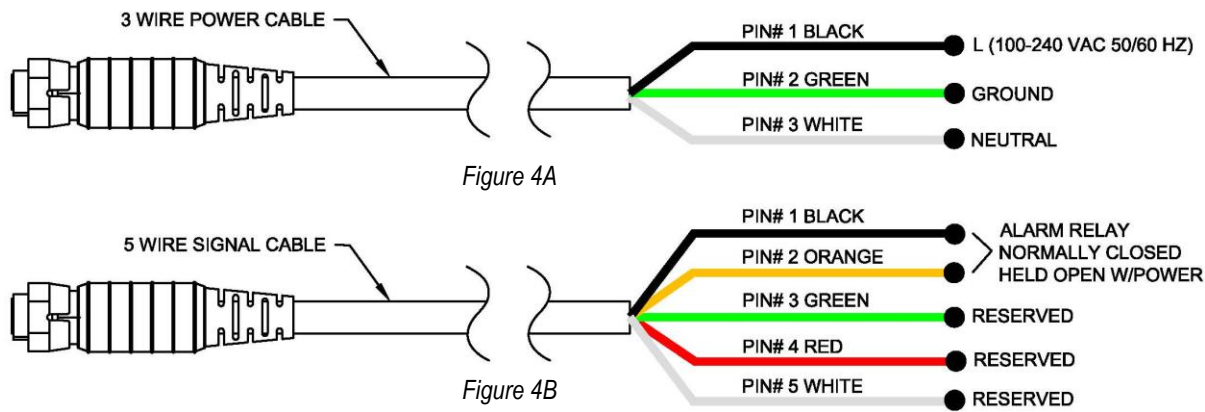

Relay contacts (BLACK-ORANGE): 4A@125VAC or 4A@30VDC

Figure 4 – Alarm and Power Connections

1. Locate the three-wire over-molded harness assembly. Terminate the white and black flying leads to the power source terminals and the green wire to the ground terminal, Figure 4A above.
2. Plug the three-wire harness into the three-wire receptacle on the left side of the breather as shown in Figure 3 on page 10.
3. Alarm connections are not required for ARDB2 operation. If used, proceed to step 4 below. If not, proceed to STARTUP on next page.
4. Locate the five-wire over-molded harness assembly. Terminate the required alarm connections as shown in Figure 4B above.
5. Plug the five-wire harness into the five-pin receptacle on the right side of the breather as shown in Figure 3 on page 10.
6. Proceed to STARTUP on next page.

STARTUP

IMPORTANT: Make sure the unit has been properly installed according to the Installation Instructions included in this manual.

⚠ CAUTION When the unit becomes energized, the controls will proceed with a regeneration cycle. The unit will quickly become hot to the touch.

1. Verify all electrical connections are securely fastened and the breather is securely mounted in an upright position.
2. Energize breather
3. Verify that green LED is lit. This may immediately turn to amber signifying a heating cycle has been initiated (assuming transformer is not inhaling).
4. Verify heating occurs within 10 minutes. The globe should be warm to touch.
5. The unit is ready for operation.
6. Proceed to ALARMS AND TROUBLESHOOTING and MAINTENANCE sections on following pages.

Regeneration Frequency

The ARDB2 system is Factory set for optimum performance and adjustments are limited to the preferred timer-based regeneration frequency. The timer-based regeneration cycle is factory set for a frequency of 10 days, however, the system can be set for 5, 10, 20 or 40 day cycles.

To Change the Regeneration Frequency

1. Ensure that the unit is de-energized from the power source.
2. Remove the four screws from the front access cover and lay off to the side. Be careful with the wires connecting the LED PCB.
3. Locate the DIP switch control and switch all four DIP switches to the OFF position.
4. Switch **ONLY ONE** of the four dip switches to the “on” position for the desired frequency:
 - a. Switch 1 – 5 day Frequency
 - b. Switch 2 – 10 day Frequency
 - c. Switch 3 – 20 day Frequency
 - d. Switch 4 – 40 day Frequency
5. Install front cover and tighten the four screws.
 - a. **Maximum torque on the cover screws is 40 in-lbs.**

NOTE: Picture shows regeneration DIP switch set for 10 day cycle.

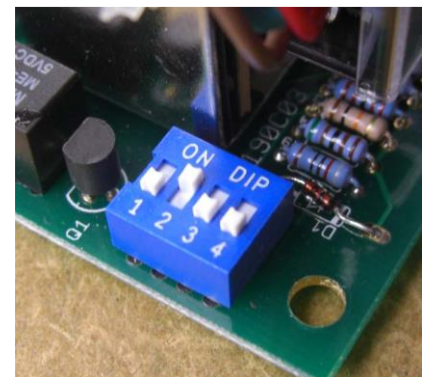

⚠ CAUTION Only one switch can be in the ON position or breather malfunction will occur.

ALARMS AND TROUBLESHOOTING

The ARDB2 system features LED indicator alarm contacts that can be used to monitor the condition of the system externally. The following table lists each alarm, corresponding condition and recommended action for the system. NOTE: Units manufactured prior to 6/30/2010 have ONLY “Heater ON” monitored relay, rated at 120VAC/30VDC.

LED INDICATOR	CONDITION	FEEDBACK CONDITION	ACTION
Local Alarm Indications			
Green	Breather is in normal standby mode and tank is breathing normally through desiccant	Local Indication	None
Amber	Regeneration Mode	Local Indication	None
Blinking Amber	Humidity Sensor Error	Local Indication	Decrease breather time-based frequency; Perform humidity service See Appendix A on page 15
Blinking Red	Vacuum Switch Failure	Local Indication	See Appendix B on page 21
Remotely-Monitored Alarm Indications (see Figure 4 on page 13 for wiring)			
Blinking Red	Breather Air Path Obstructed or Vacuum Switch Failure	Alarm Relay Contacts CLOSED	See Appendix B on page 21
Red	Heater Element Failure	Alarm Relay Contacts CLOSED	Contact Factory
Red	Solenoid Valve Failure	Alarm Relay Contacts CLOSED	Contact Factory
None	Power Failure	Alarm Relay Contacts CLOSED	Investigate Power Failure

Table 2 –Local and Remote Alarm Indications

INSPECTIONS / MAINTENANCE

The ARDB2 system is a self-monitoring system that requires minimal maintenance. Periodic inspection is required to ensure that the system is operating at optimum efficiency.

Annual Inspection

1. Remove bottom vent drain and inspect for restrictions such as dust or other contaminants.
2. Clean or replace bottom drain vent, as necessary (Waukesha P/N 1030-1661).
3. Remove side vent and inspect for restrictions such as dust or other contaminants.
4. Clean or replace side vent, as necessary (Waukesha P/N 1030-1787).
5. Visually inspect desiccant for contamination, particularly oil that will show up as a dark or blackened desiccant color. The desiccant should be a clear color. If the desiccant is saturated, the timer regeneration frequency should be decreased (see STARTUP section on page 12).
6. If desiccant is oil contaminated, desiccant must be replaced (Waukesha P/N 1030-1797).
NOTE: The small breather uses 1 bag of P/N 1030-1797, & the large breather uses two bags of P/N 1030-1797.
7. Clean breather globe if necessary.
8. If the control cover is removed, the Maximum torque on the cover screws is 40 in-lbs.

⚠ CAUTION Only mild soap and water should be used to clean the globe. Solvents must not be used for any reason, as they will degrade the performance of the polycarbonate material. *Use of solvents on the unit will immediately void warranty.*

Every Five Years Inspection

1. Replace bottom and side vents as described in annual inspection section above.
2. **For Units Manufactured Prior to June 2010:** Remove bottom vent and inspect ball float operation. Use the rubber end of a pencil to ensure ball moves freely from sealing surface. This ensures that condensed moisture is properly draining from the assembly.
3. Ensure all connections are secure and fill cap is properly tightened on assembly.
4. Visually inspect desiccant for contamination, particularly oil that will show up as a dark or blackened desiccant color. The desiccant should be a clear color. If the desiccant is saturated, the timer regeneration frequency should be decreased (see STARTUP section on page 12).
5. If desiccant is oil contaminated, desiccant must be replaced (Waukesha P/N 1030-1797).
NOTE: The small breather uses one bag of P/N 1030-1797, & the large breather uses two bags of P/N 1030-1797.
6. If the control cover is removed, the Maximum torque on the cover screws is 40 in-lbs.

APPENDIX A: Humidity Sensor Service (Blinking Amber)

1. Disconnect power from the ARDB2 to be serviced.
2. Remove the top fitting and place aside.

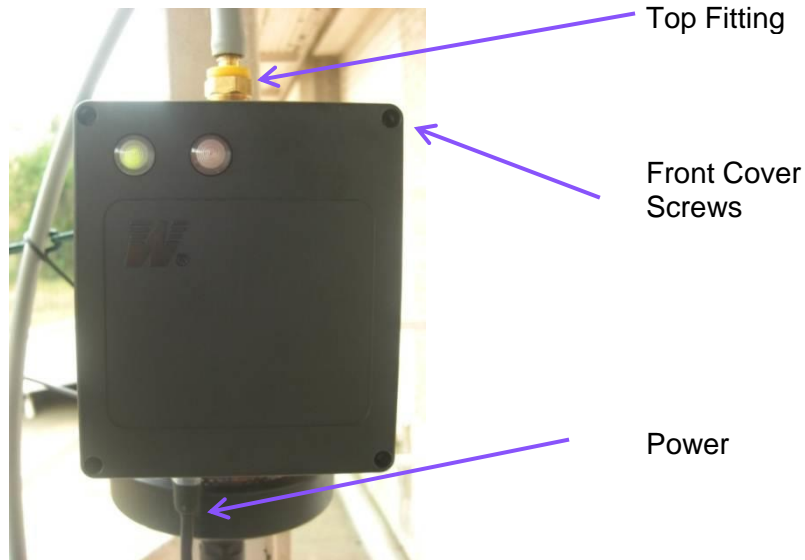

3. Remove the four lid screws and place the removed lid carefully on top of the unit with the top fitting.

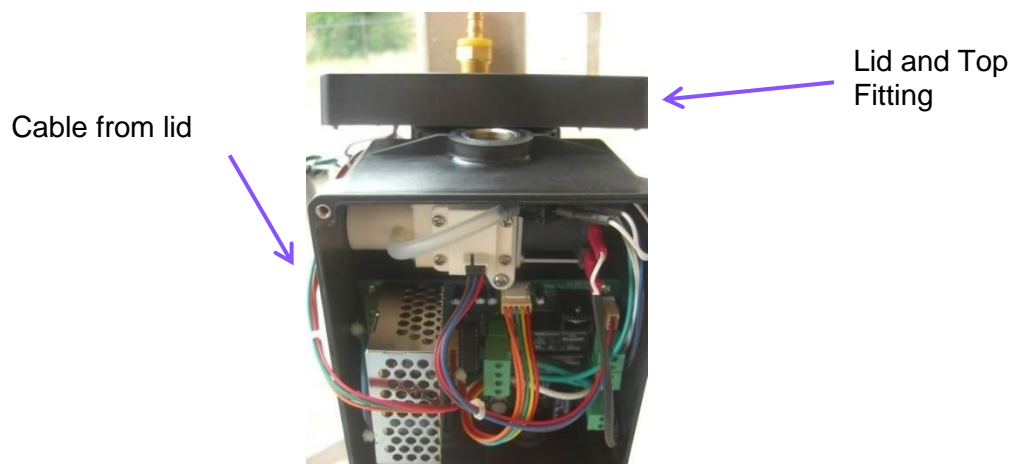

APPENDIX A (continued)

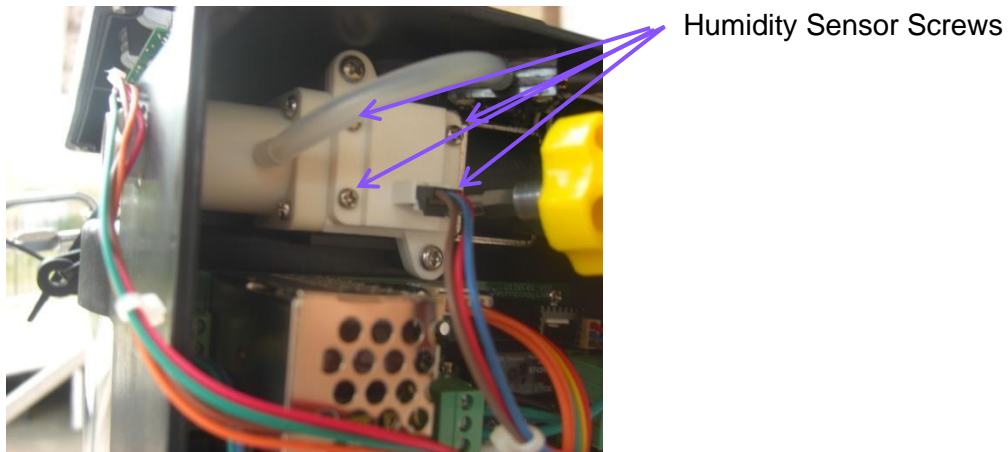

4. Remove the four screws from the corners of the humidity sensor and carefully place aside.

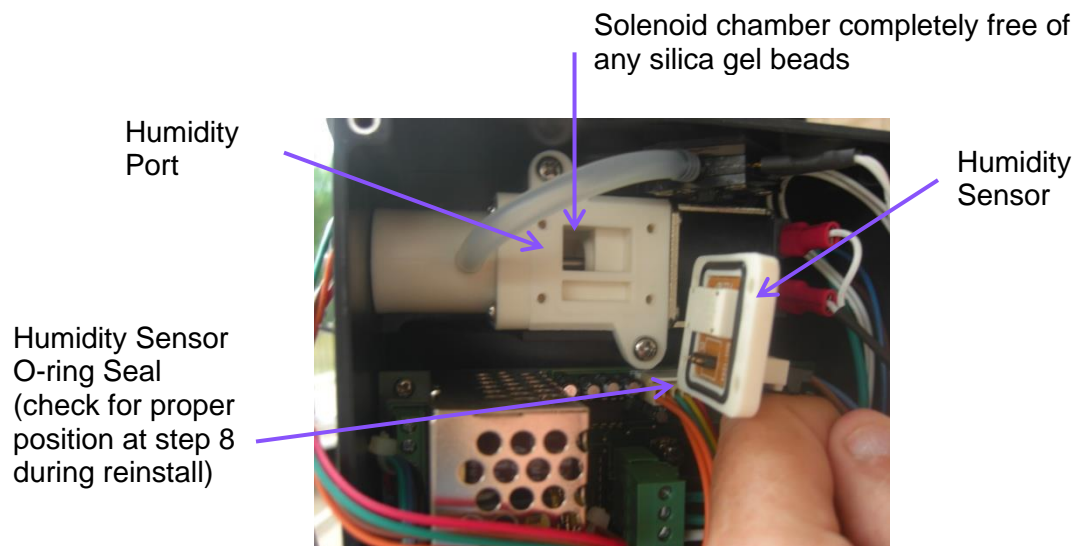

5. Gently remove the humidity sensor using the cable as a holder. Check for presence of silica gel beads in solenoid chamber and remove the gel beads if found.

APPENDIX A (continued)

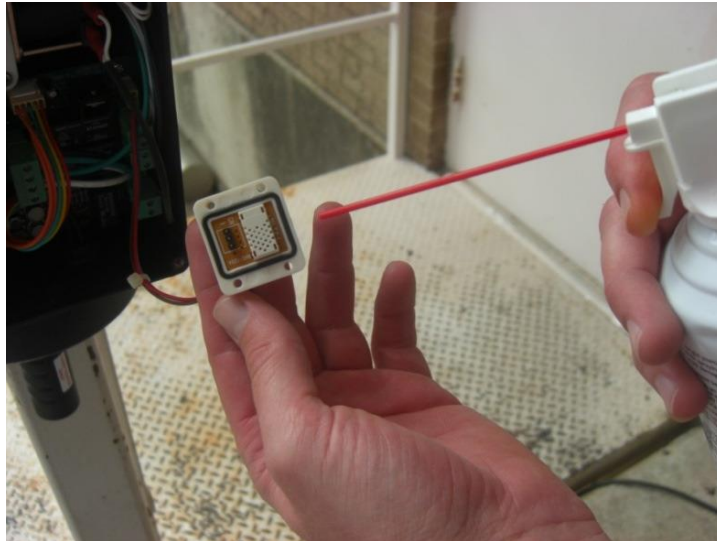

6. Using canned dry air, gently blow any moisture from the humidity sensor.

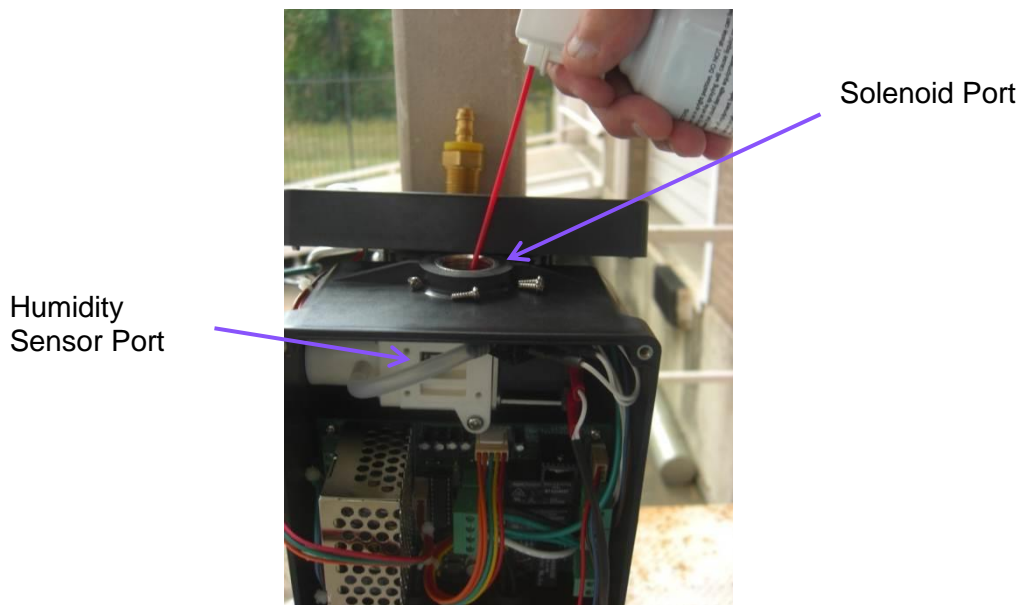

7. Using the same dry canned air, blow any excess moisture out of the solenoid and humidity sensor ports.

APPENDIX A (continued)

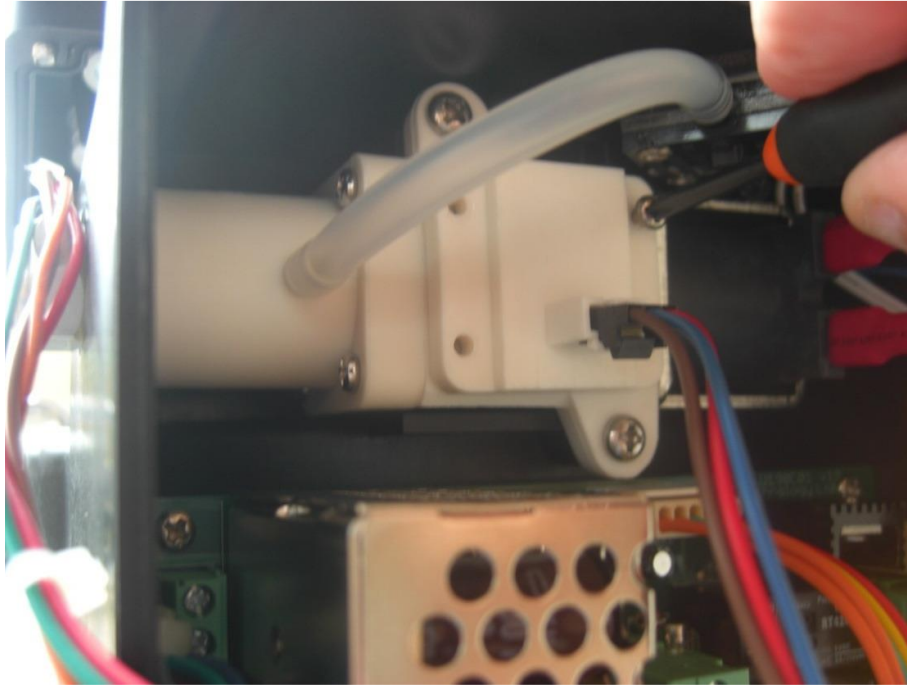

8. Re-install the humidity sensor and sensor cover screws.

NOTE: The cabling is at the bottom of the sensor. Tighten the screws snugly, but do not over-tighten.

APPENDIX A (continued)

Lid Gasket

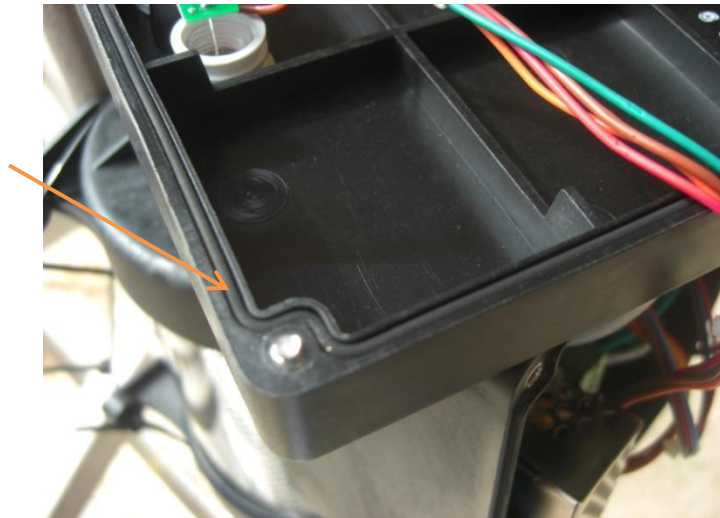

9. Prepare to re-install the front lid. Check that the lid O-ring gasket is still firmly positioned in the lid groove.



9. Holding the lid flat and in place, re-install the four lid screws & tighten the screws snugly. DO NOT over-tighten. The Maximum torque on the cover screws is 40 in-lbs.

APPENDIX A (continued)



10. Re-install the top fitting tightly using Teflon tape or an equivalent pipe sealant.
11. Re-install the power line and reconnect power to the unit.
12. The GREEN light should flash for 1 second & then the AMBER light should come on to signal a regeneration cycle. The AMBER light should remain on during the regeneration cycle.
13. If ALL excess moisture has been removed but the AMBER light continues to blink, the humidity sensor is defective and needs to be replaced (contact factory at 800-338-5526).

NOTE: Breather will **STILL FUNCTION** on timed regeneration cycle with a blinking AMBER light. All other controls are still functioning which will ensure proper operation on a timed regeneration cycle.

APPENDIX B: Air Path Obstructed or Vacuum Sensor Error (Blinking Red)

1. Remove power from the unit for 60 seconds.
2. Reconnect power. If the blinking RED indicator returns, again remove power for an additional 60 seconds.
3. If the blinking RED light persists,
 - a. Remove the power from the ARDB2.
 - b. Check the breather for an obstructed air path. An obstruction can be verified by removing the hose connected to the top of the breather that leads to the conditioned space. Using compressed air, blow into the upper breather opening.
 - c. You should be able to detect air exiting the breather via the normal air entrance slots around the periphery of where the globe enters the top housing.
 - d. If you detect air, then the air path is clear. If you do not detect airflow then the air path is obstructed, contact the factory at 800-338-5526 for further information.
 - e. The problem is a defective vacuum sensor; contact the factory at 800-338-5526 for a replacement vacuum sensor.
 - f. At this time, you should remove and inspect the side exhaust vent. Clean or replace.

APPENDIX C: Flange Mount Installation

1. If your transformer has breather piping which ends in DIN 42562-5 flange with integral gasket, order the ARDB2 as follows:
 - If your breather pipe has a DIN 42562-5 flange, order the ARDB2 with Connection Option **#3**.
 - Connection Option **#3** comes with a flat flange, flat gasket & down pipe to connect to the ARDB2 breather and securing hardware. The flat gasket may be used as needed for the installation.
2. Installation with either of the connection options above is straight forward.
 - a. Verify that the existing breather piping is clean and clear of debris and/or transformer oil contamination; if debris or contamination is introduced to the ARDB2; warranty will be void and could cause failure of the ARDB2.
 - b. Install the flange down pipe to the ARDB2 top port. Use of thread sealant is required to prevent leaks.
 - c. Install the included side port filter. The top port and side port on the breather **MUST** be sealed before installing the desiccant.
 - d. Remove top cap and pour silica gel (included) into breather. Small breather requires 2.2lbs/1kg if desiccant and large breather requires 4.4lbs/2kg of desiccant. Replace cap and ensure it is locked in place.
 - e. Install the ARDB2 using the flange plate and included hardware. It is critical to the operation of the ARDB2 that it is installed in the vertical position.
 - f. Install temperature and caution labels. Locate these labels on the globe in the areas best visible to service personnel (dependent upon mounting location).
 - g. See Figure C1 on following page for a typical flange installation.

APPENDIX C (continued)

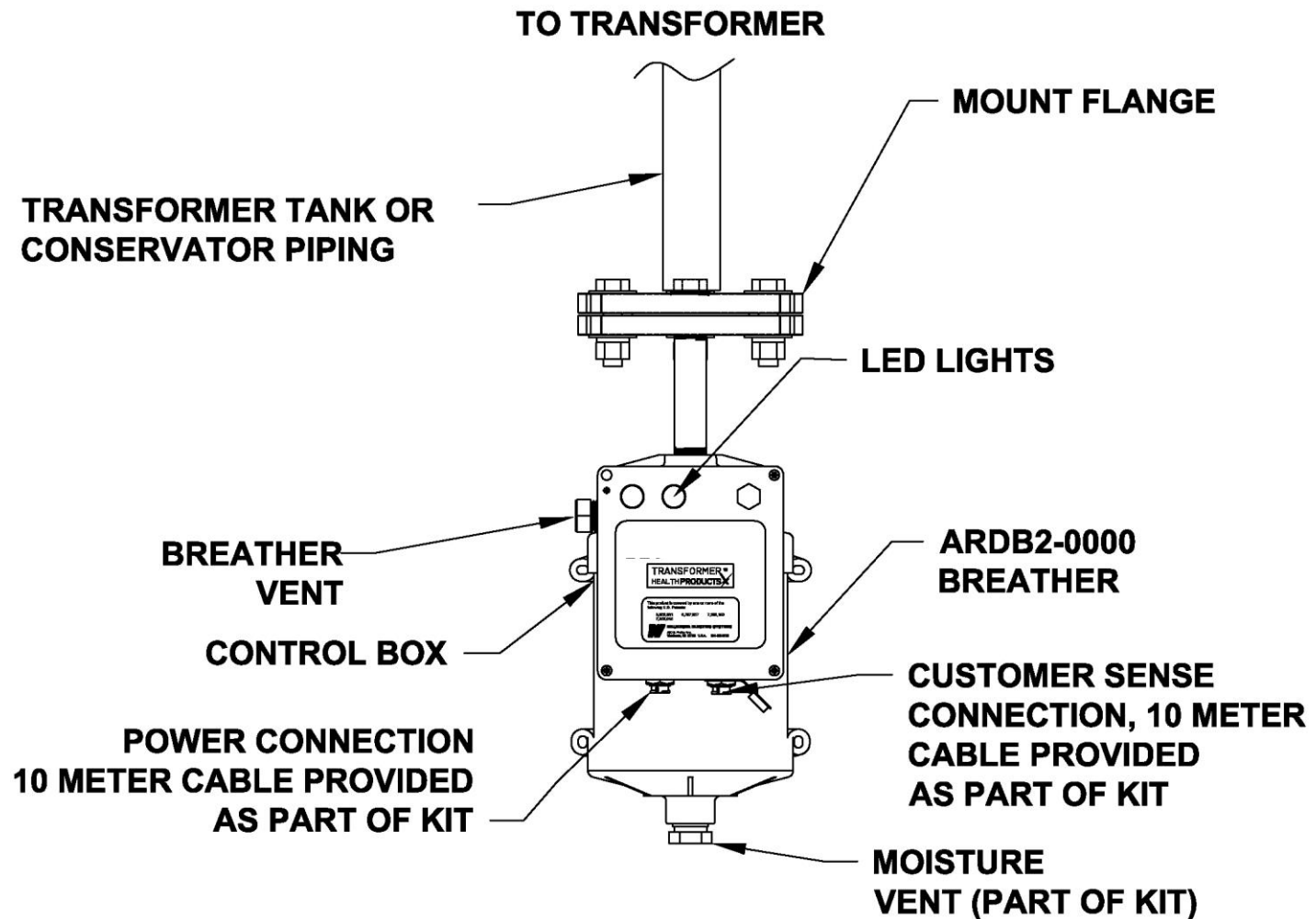

Figure C1 – Typical ARDB2 Flange Installation

APPENDIX D: ARDB to ARDB2 Mounting

To install an ARDB2 2ND Gen. Breather on the control cabinet of an ARDB 1ST Gen or an MFDB Breather without making modifications, Connection Option #4 is required (see Figure D1 below for adapter kit components).

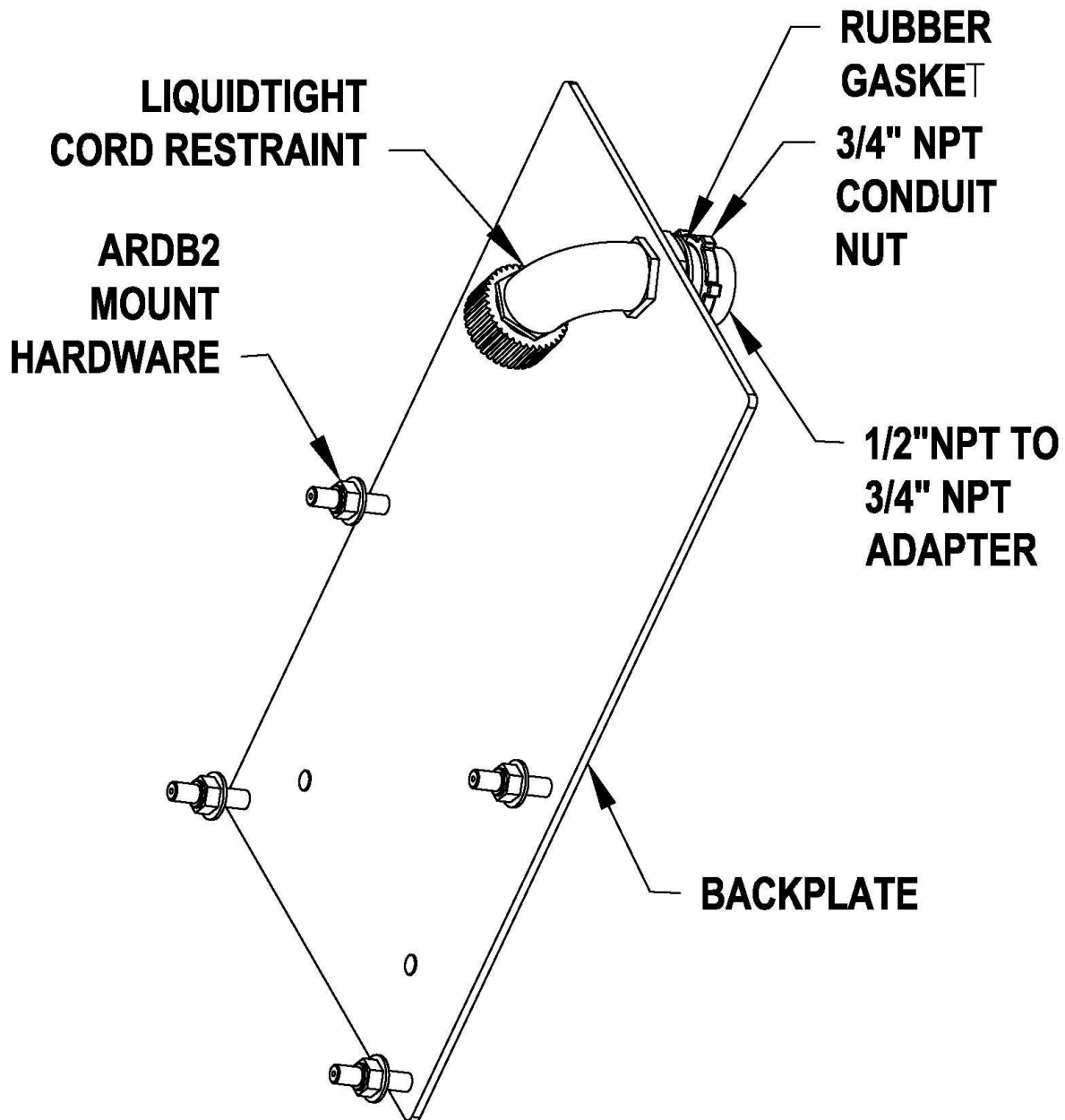

Figure D1 – ARDB2 to ARDB or MFDB Mounting Adapter (Part Number 1030-1636)

APPENDIX D (continued)

1. Assemble the ARDB2 to ARDB mounting adapter:
 - a. Place the liquid tight cord restraint through the hole in the back plate at about 45° angle from horizontal.
 - b. Tightly screw the ¾" NPT to ½" NPT adapter on to the threaded end of the liquid tight cord restraint that is extending from the back of the mounting plate. Ensure this is tightly fastened to secure the liquid tight cord restraint in its position on the back plate.

2. Install the ARDB2 mounting adapter (NOTE: Remove power from the cabinet before continuing):
 - a. Fit the threaded end of the ¾" NPT adapter through the hole in the cabinet that previously held the ARDB.
 - b. Thread the ¾" NPT conduit nut onto the ¾" NPT adapter that is extending into the cabinet.
 - c. Tightly fasten this conduit nut to secure the ARDB2 adapter plate in position such that the ARDB2, when mounted, will be in the upright and vertical position.
 - d. Place the ARDB2 over the four studs in the front of the adapter plate. Secure the ARDB2 using the flat washers and NyLoc nuts provided.
 - e. Attach the three-conductor power cable to the ARDB2 and run the loose end through the liquid tight cord restrainer and grommet by loosening the knurled nut.
 - f. Once the cable is fed through the liquid tight cord restrainer, tighten the knurled nut on the restrainer to achieve a liquid tight grip on the power cord.
 - g. Shorten the power cord as required in the cabinet and connect the black lead to the power line, the white lead to the neutral and the green lead to a solid ground.
 - h. NOTE: The remote alarm, five-conductor cable once attached to the ARDB2 needs to be connected separately to a monitoring system (see Figure D1, page 24), as the liquid tight cord restraint will not accommodate a second cable.
 - i. See Figure D2 on the following page for a typical ARDB2 to ARDB adapter mounting.

APPENDIX D (continued)

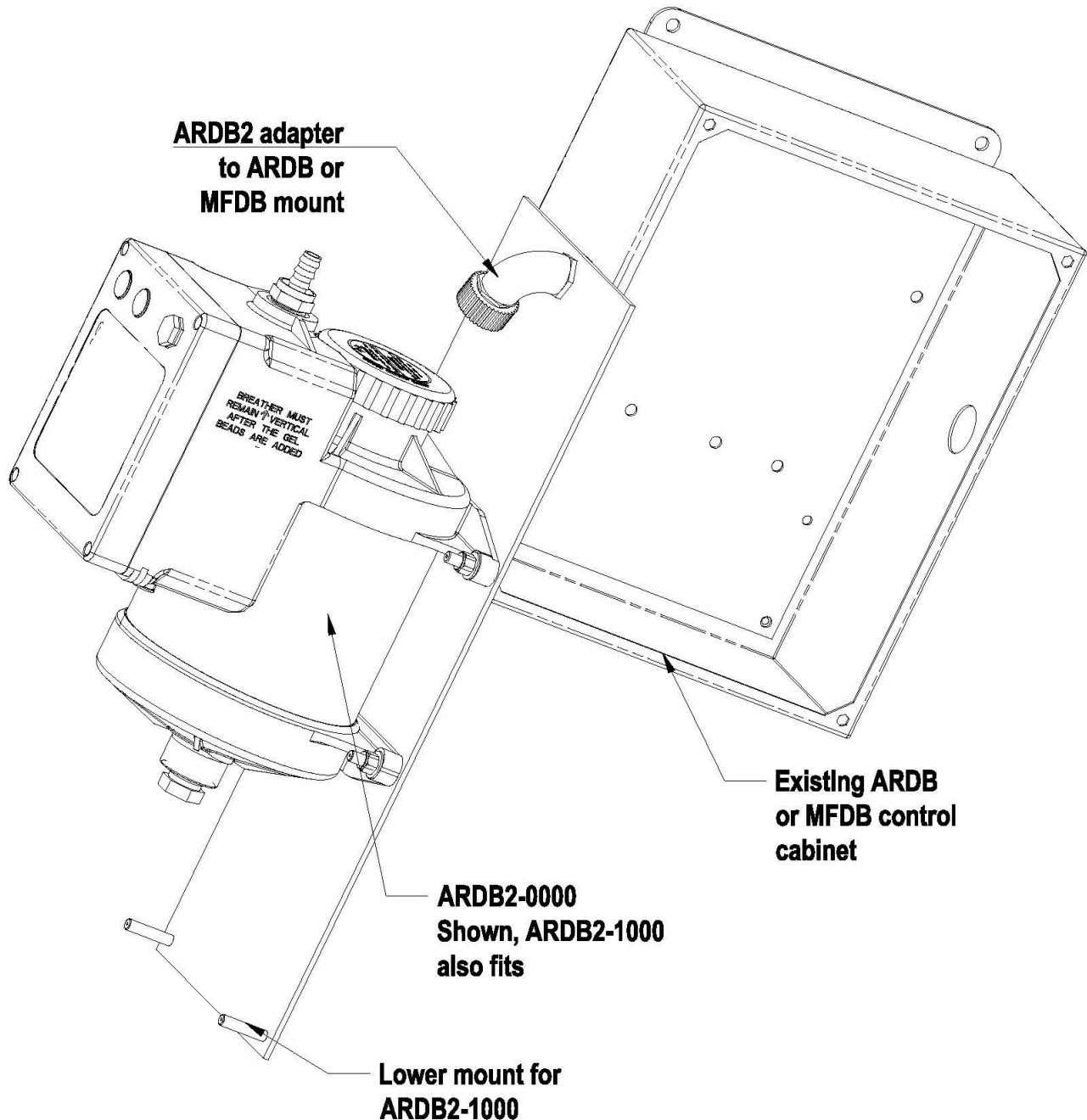

Figure D2 – Typical ARDB2 to ARDB or MFDB Mounting (Adapter Part Number 1030-1636)

APPENDIX E: Optional Conduit Box Adapter Wiring



APPENDIX E (continued)

- Remove the (4) screws holding the lid to the Conduit Box Adapter and remove the lid.
- Remove the lid.
- Install the necessary conduit adapters into one or both of the 22mm access holes
- Run the necessary wiring and attach the wiring per the wiring diagram below by loosening the respective terminal block screws (**on the labeled side ONLY**), inserting the respective conductors and then retightening the terminal block screws.
- Proceed to the Testing Procedure.

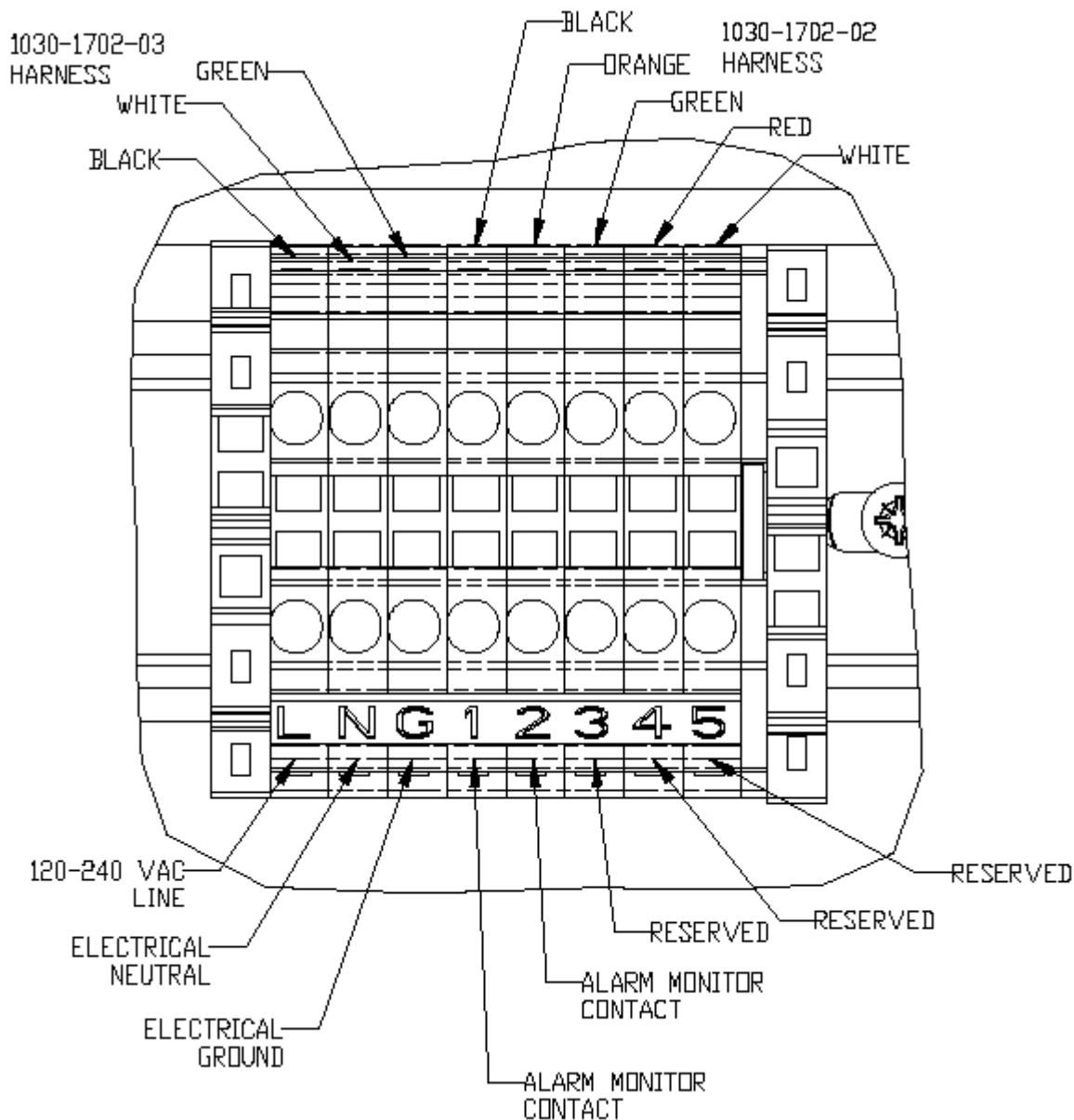

APPENDIX E (continued)

- **Test Procedure**
- **Do NOT Apply POWER:**
 - With no power applied there should be a closed circuit between the (2) Alarm Monitor terminals connected to terminal blocks 1 & 2.
 - If it is OPEN the possible causes are:
 - The leads from the control box are not making proper contact in the terminal blocks.
 - The leads from the control box are not connected to the correct terminal blocks.
 - The plug on the cable harness is not properly seated on the PWB connector.
 - The ARDB2 unit is defective.
- **Apply POWER**
 - The GREEN LED should come ON for about 1 second.
 - The AMBER LED (heating) should come ON and stay ON.
 - **Monitor the unit for about 30 seconds to ensure that the unit is clear of any error messages.**
 - With power applied, the circuit between the 2 Alarm Monitor connections should be OPEN.
 - If it is not an OPEN circuit:
 - The leads from the control box are not making proper contact in the terminal blocks.
 - The leads from the control box are not connected to the correct terminal blocks.
 - The plug on the cable harness is not properly seated on the PWB connector.
 - The ARDB2 unit is defective.
- If the unit passes testing, reinstall the Conduit Box Lid & secure with the (4) corner screws.
- The Maximum torque on the cover screws is 40 in-lbs.

REPLACEMENT PARTS AND SERVICE

Please contact your local sales representative or authorized distributor for replacement parts and/or service, or visit us online at www.waukeshacomponents.com.

For technical support, call us at 800-338-5526.

