

2ND GENERATION

Positive Temperature Coefficient Heater

Smaller, Faster, Easier Temperature Control Without a Thermostat

Waukesha® Positive Temperature Coefficient Heaters (PTC2) can improve the reliability, efficiency and operational life of electrical equipment by automatically maintaining an enclosure temperature only slightly higher than the outside ambient temperature without using a thermostat or controls. Our PTC2 performs this function with a high velocity fan, all while taking up less space and having no need for any special mounting platforms.



Customer Configurable

SEE BACK SIDE FOR PART NUMBER CONFIGURATION TOOL.

ELIMINATES THERMOSTAT PROBLEMS

Our PTC2 heaters use a variable resistance (current limiting) material that automatically controls cabinet temperature and eliminates the need for a thermostat, increasing heater reliability and efficiency.

PREVENTS HEAT DAMAGE AND CONDENSATION

During cold weather when significant heat is required to reach the thermostat setting, a traditional strip heater is likely to drive the temperature of the area around the heater well above desirable levels. This can result in uneven heat distribution in the control box. Waukesha® PTC2 heaters feature an integral circulating fan that moves warm air around the cabinet, maintaining even heat distribution and providing uniform condensation protection. The PTC2 offers even better air velocity than the previous PTC, allowing for even more air movement throughout the cabinet.

INSTALLS QUICKLY

The electrical connections from the fan to the heater are pre-wired, so the only necessary connection is to provide power to the assembly; our forced air PTC2 heaters include a 12 foot long wire harness with quick-connect end for easy installation. Integrated DIN-rail mounting clip allows for quick orientation in cabinet for proper air circulation.

ADDITIONAL FEATURES

- Economical
- Energy efficient — low power consumption
- Low electrical noise
- Low profile — compact size
- Plastic heater guard to help prevent burns
- UL recognized (E216910, E466674)

PTC2 HEATERS ARE AVAILABLE IN THE FOLLOWING CONFIGURATIONS:

- 20, 30, 40 & 65 watt — dual rated for 120V–240V
- 200 watt, fan forced*
- 300 watt, fan forced*
- 400 watt, fan forced*

* Specify either 120V or 240V.



Snap-together connection between harness and heater further simplifies installation.

Build Your Own Part Number Using Configuration Below

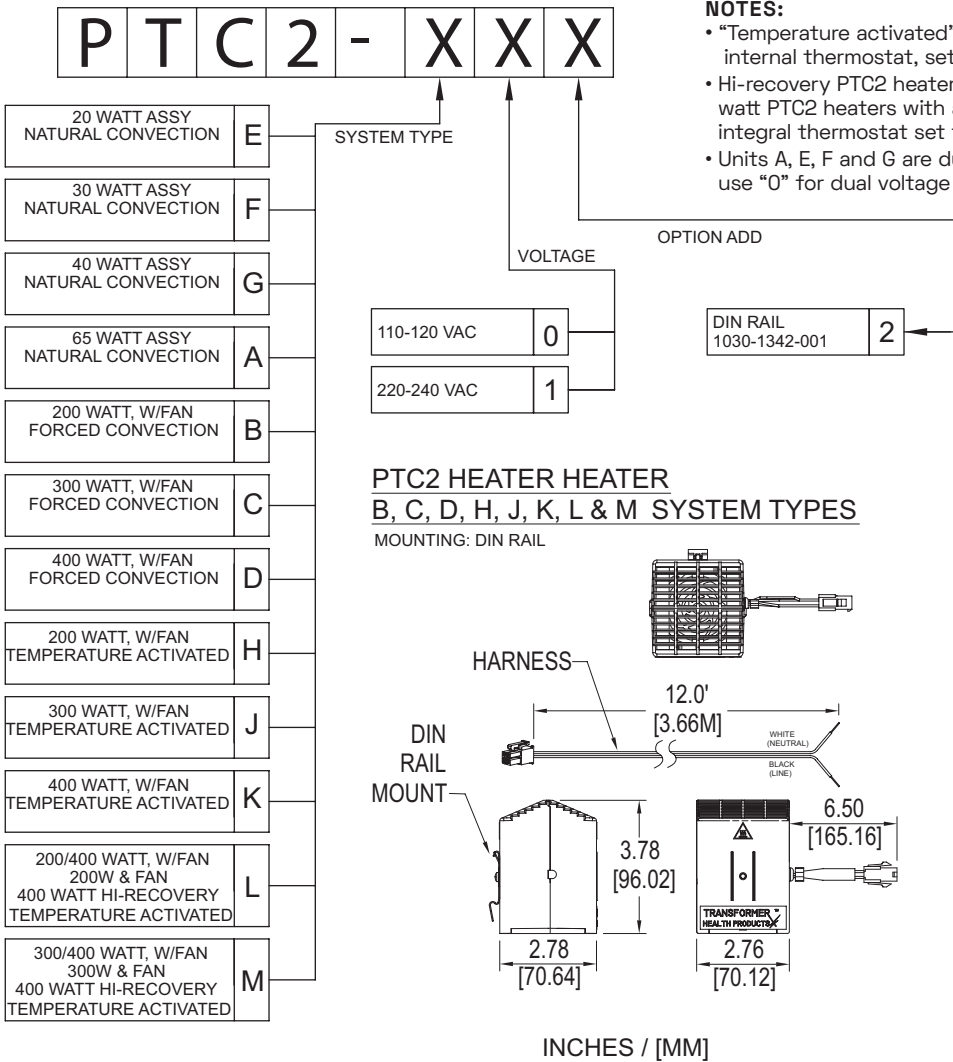

NOTES:

- "Temperature activated" PTC2 heaters are controlled by an internal thermostat, set to energize at 5°C±3°C
- Hi-recovery PTC2 heaters operate as standard 200 or 300 watt PTC2 heaters with a hi-recovery 400W mode activated by integral thermostat set to energize at 5°C±3°C
- Units A, E, F and G are dual-rated for 120V-240V service; use "0" for dual voltage selection

PTC2 HEATER A & G SYSTEM TYPES

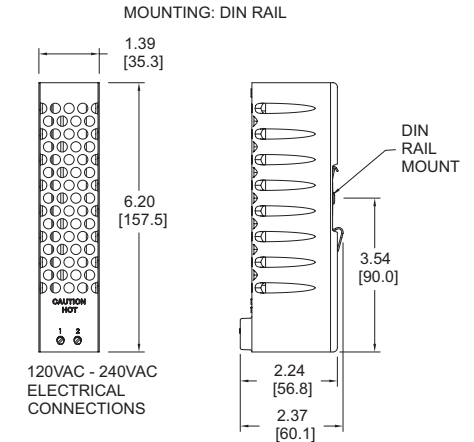

PTC2 HEATER E & F SYSTEM TYPES

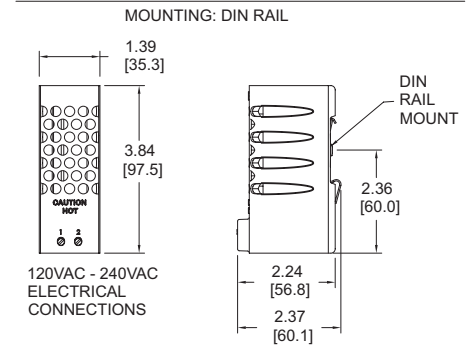

HOW TO PICK YOUR OWN HEATER

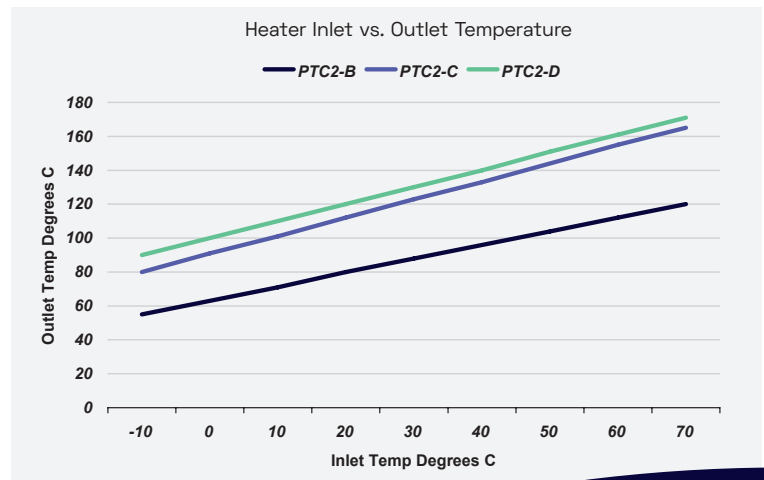
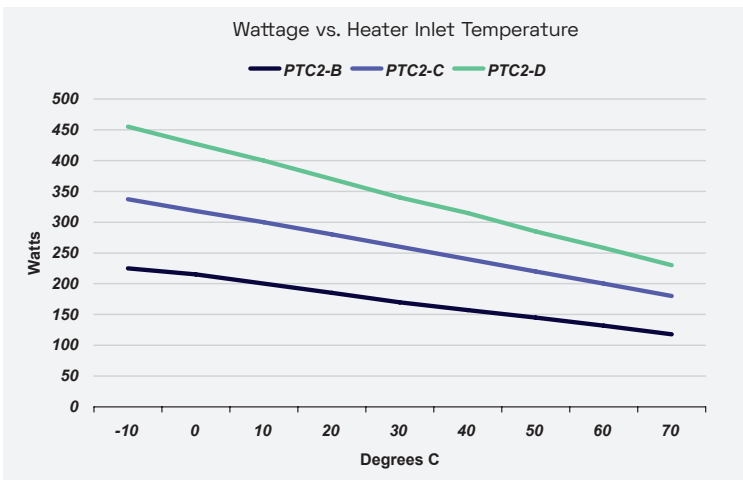

Contact us for more information. To download a technical manual, field maintenance manual and/or technical paper, visit our website.

To continually improve its products and services, Prolec-GE Waukesha, Inc., reserves the right to change specifications and features without notice. Please contact us for certified dimensions and drawings.

LOCATION
Prolec-GE Waukesha, Inc.
9011 Governors Row
Dallas, TX 75247
800-338-5526

waukeshacomponents.com

transformers | service | training | components

