

January 4, 2018

WESTINGHOUSE UTT UPGRADE SERIES

Upgrading your UTT, UTT-A or UTT-A70 to the UTT-B and RMT-1 Style Transfer Switches

In this white paper, we will discuss possible upgrades for the transfer switch assembly on the Westinghouse UTT Series load tap changer (LTC). These upgrades address areas of the transfer switch that are prone to failure due to overheating and carbon buildup and are applicable to the UTT, UTT-A, UTT-A70 and UTT-B models. Form, fit, and function of these upgrades are of the highest quality available.

Each phase of a 3-phase UTT LTC contains two transfer switch assemblies. Figure 1 below contains 3-D models of individual phase panels for each of the different UTT Series LTC models. Red arrows indicate areas where overheating and coking typically occur. These arrows also help visually identify areas where differences exist in the individual model designs. Additionally, the area of the phase panel that includes the transfer switches has been identified in a red rectangle.

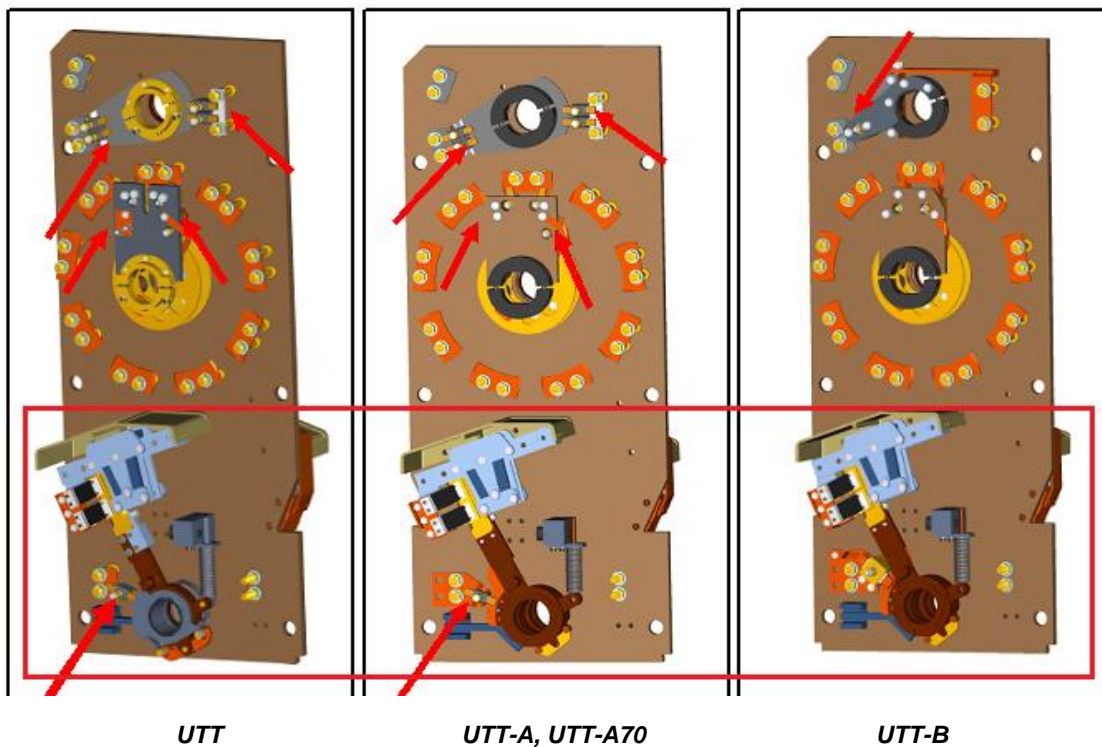

Figure 1

Figure 2 below depicts the transfer switch portion of a UTT phase panel. The stationary and moving contact portion of the transfer switch assemblies are circled for ease of identification. You will note that two transfer

switch contact assemblies are included for each phase, one on either side of each phase panel. When standing in front of the open inspection door, the front transfer contact assembly on each phase is readily visible on the right hand side of each phase panel and can be easily inspected. The second transfer contact assembly for each phase is more difficult to inspect, as it is in the back of the compartment and is most often obscured from sight by the leads. In order to complete a thorough inspection, care must be taken to inspect all six transfer switch contact assemblies.

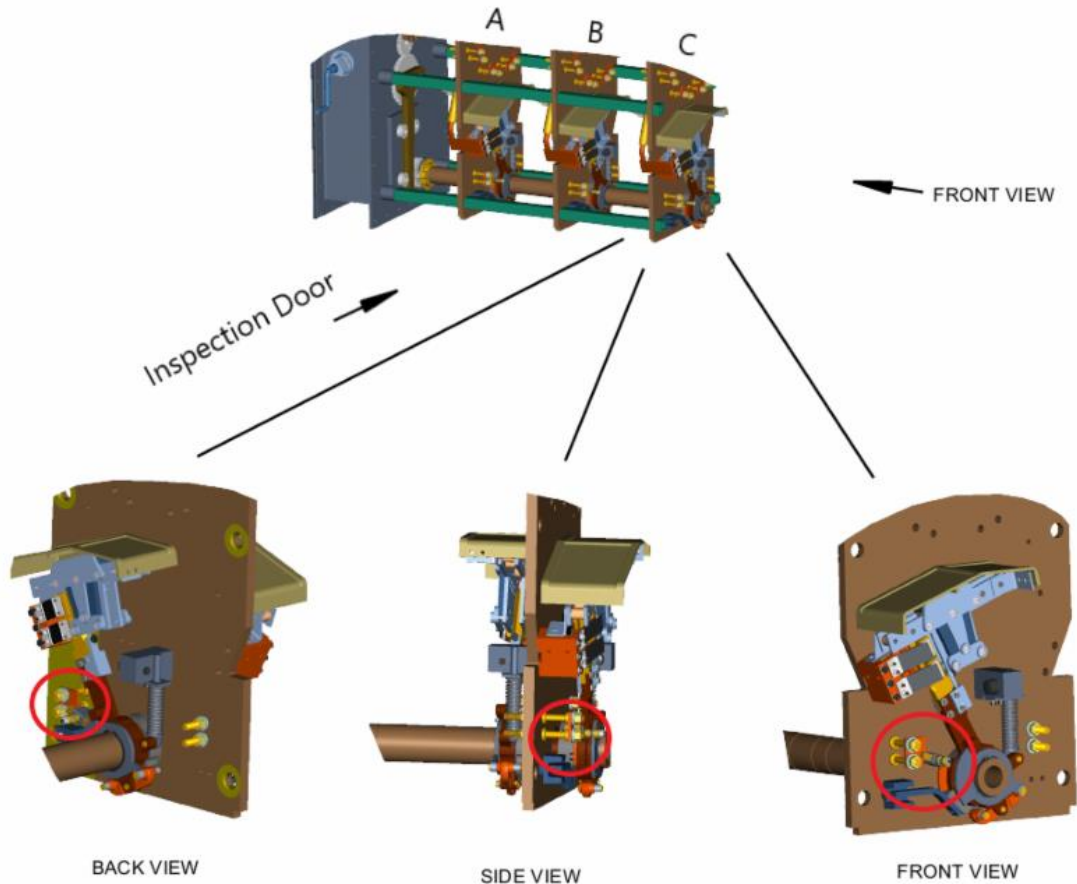

Figure 2

By upgrading the transfer switch contact assemblies of the UTT, UTT-A and UTT-A70 to the UTT-B design, the risk of overheating and carbon buildup in the stationary contact areas is fundamentally reduced. Figure 3 below depicts the transfer switch stationary contact assembly of a UTT. While slight differences exist between the UTT, UTT-A and UTT-A70 designs, the UTT design is sufficient to represent all three for the purpose of illustrating the improvements incorporated into the UTT-B design. Figure 4 shows the improved transfer switch stationary contact assembly of the UTT-B. The transfer switch stationary contact assembly design utilized in the UTT-B is the same design that was applied in the RMT-1. When comparing the two transfer switch

stationary contact assemblies presented in Figures 3 and 4 below, the following design enhancements are readily evident:

- Cross sectional area of the stationary contact fingers is significantly larger in the UTT-B design, thereby resulting in a sizable increase in current carrying capability
- Stationary contact plates of the UTT-B design are substantially larger, yielding more surface area immersed in oil; as a result, the amount of heat dissipated in the oil is much greater in the UTT-B design
- A braided copper jumper has been incorporated into the UTT-B design, allowing the primary flow of current to be from the finger contact into the plate thus bypassing the static spring-loaded joint of the finger contact

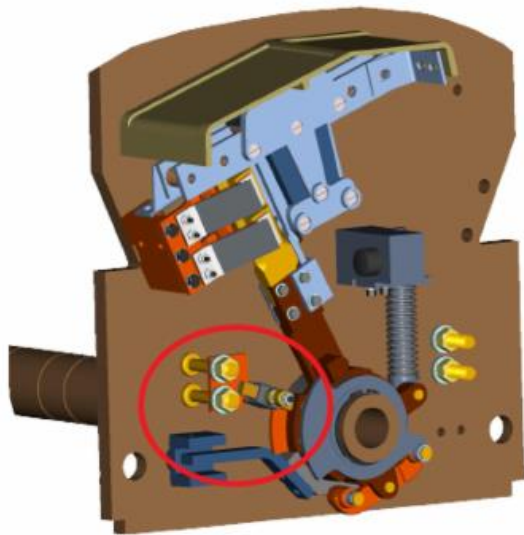

Figure 3: UTT Transfer Switch

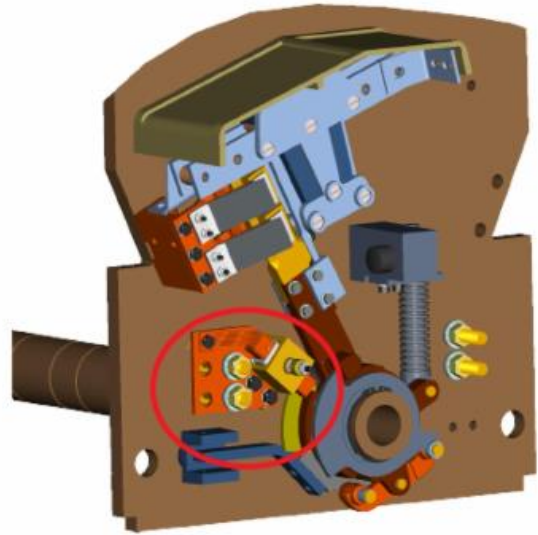

Figure 4: UTT-B / RMT-1 Transfer Switch

AUTHOR:

Damon Jones

General Manager – Components Group

Damon Jones joined Prolec GE Waukesha in April 2017 as General Manager for the Components business in Dallas, Texas. Damon started his career with Siemens in 1999 and spent 15 years serving the domestic and international power generation/transmission/distribution markets. During that time, he held positions of increasing responsibility in sales, product development, project management and general management, both domestically and abroad. Damon holds a Bachelor of Science Degree in Mechanical Engineering from Clemson University and a Masters of International Business Studies from the University of South Carolina.

Each upgrade kit from Waukesha® Components comes with detailed instructions for installing the upgraded designs. We also offer standard and customized component kit cases. These cases offer the following unique set of benefits:

- Parts are easier to pull from inventory and issue to the maintenance jobs
- All key parts are included for easy and safe transport to the work location
- No need for field personnel to keep lists of components consumed during maintenance
- Cases provide a better means of protection and storage for the components
- Quick and easy to replenish after completion of field maintenance

To learn more about all upgrades available for the UTT Series LTC, visit our website at <https://www.waukeshatransformers.com/> or contact a member of our sales team at 1-800-338-5526. Also, don't forget about our library of [easy-to-navigate, 3D catalogs](#) designed to help you quickly identify and locate hard-to-find components for LTCs and oil circuit breakers, while also including one for the Waukesha® Components' line of Transformer Health Products®.



Our 30-year history of providing replacement parts for the majority of OEM LTCs has allowed us to develop the capability to confidently engineer, manufacture and support a myriad of design-enhanced replacement parts. We welcome calls from customers seeking technical support on LTCs.