

The background image shows a large, grey industrial transformer in an outdoor power plant setting. The transformer is mounted on a metal frame and has several high-voltage bushings and insulators on top. In the background, there are several wind turbines under a clear blue sky. The foreground shows a concrete base and some gravel.

# Regional Technical Seminar

## Transformer Specifications and Design

Transformer Regional Technical Seminar

Austin TX

October 1, 2024

**waukesha**  
a prolec ge company

# Manu Sandhar Electrical Design Engineer

*Manu joined Prolec GE Waukesha in July 2019 as an application engineer at our Waukesha, Wisconsin, facility. She moved to the design engineering team in January 2020, where she designs new medium power transformers, including LTC and re-connectable types. Manu earned her Bachelor of Technology, Electronics and Communications Degree from CT Institute of Technology as well as her Master of Science Degree in Electrical Engineering from the University of St. Thomas.*



# Agenda

## Requirements and their impact on design

- General Requirements
- Core Design Requirements
- Winding Design Requirements
- Short Circuit Withstand Requirements
- Dielectric Withstand Requirements
- Thermal Requirements
- Accessories and Monitoring Requirements
- Testing Requirements



# General Requirements

# General Requirements

## State the Rating Data

- Internal Cooling Medium
  - Mineral oil or Natural Ester Fluid
  - Main tank and all accessory tanks
- Cooling Class (ONAN, KNAN, ONAF, ODAF etc.)
- Frequency
- Number of Phases
- MVA Ratings for each stage of cooling (C57.12.10 – Table 1)
- Voltage and Tap Voltages
- Vector Group (C57.12.70)
- Impedance (C57.12.10)

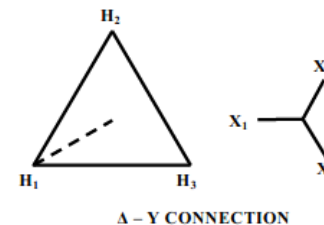
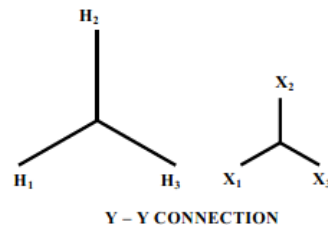

## Standards and Guides

- Know the Difference
- Know Information Required to Appropriately Specify Requirements from a Guide

Present designations	Previous designations
ONAN	OA
ONAF	FA
ONAN/ONAF/ONAF	OA/FA/FA
ONAN/ONAF/OFAF	OA/FA/FOA
ONAN/OFAF	OA/FOA
ONAN/ODAF/ODAF	OA/FOA <sup>2</sup> /FOA <sup>2</sup>
OFAF	FOA
OFWF	FOW
ODAF	FOA <sup>2</sup>
ODWF	FOW <sup>2</sup>

# General Requirements

## Unusual Service Conditions (C57.12.00-2015 Section 4.3)

- Unusual Ambient (Examples: -40C, 35C Average, 50C Max)
- Altitude greater than 3300 feet
  - Greater External Clearances
  - High Creep Bushings and Arresters
- Environment: Salt, dust, fumes
- Abnormal Vibration, tilt or shock, Seismic
- Motor Starting Capability or unusual duty
- Unbalanced loading conditions (open phase loading)
- Harmonic content in excess of 0.05 per unit
- Geomagnetically Induced Current (GIC) Requirements

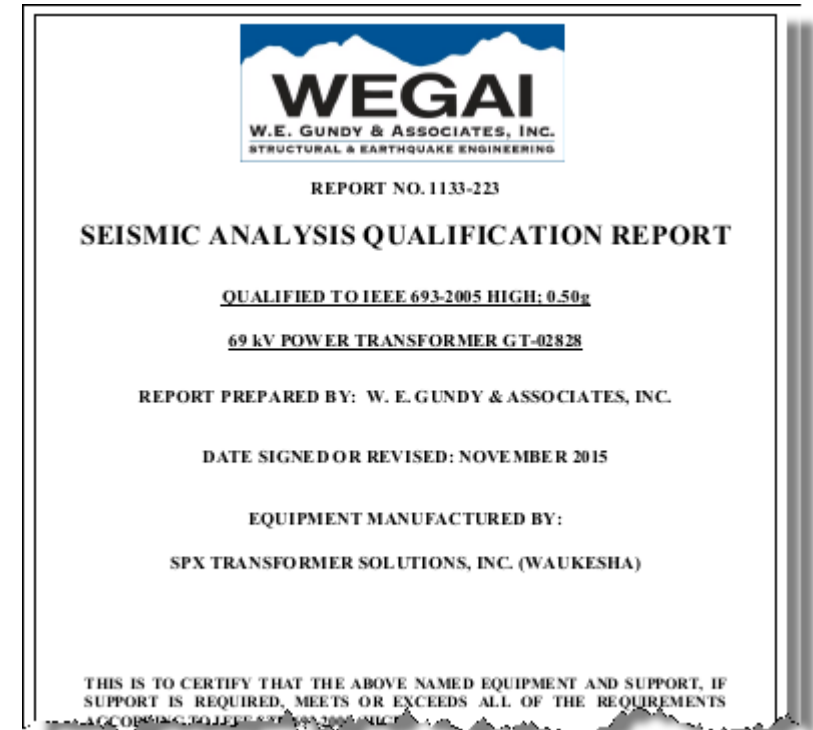

# General Requirements

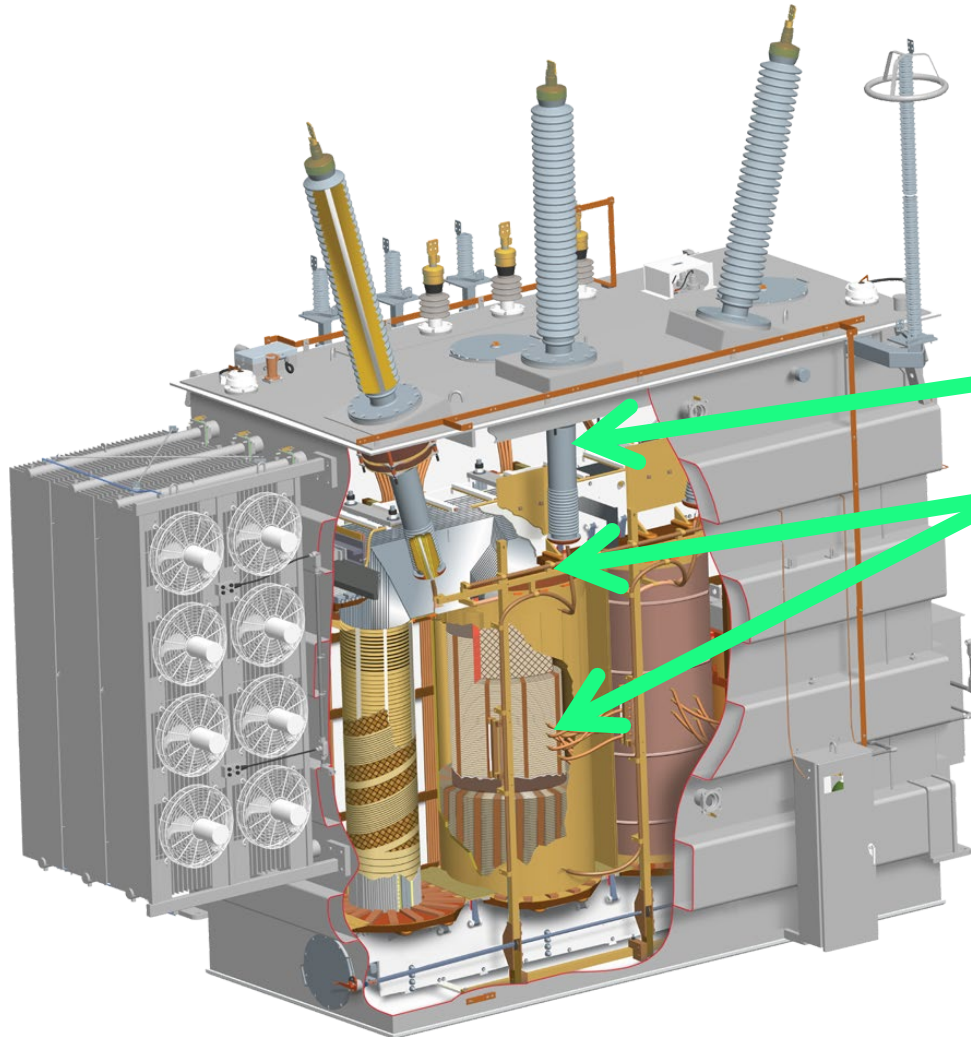

## Per IEEE:

- Max Ambient = 40C
- Max 24 hour Avg. Ambient = 30C
- Min Ambient = -20C
- Top Oil Temperature = 95C
- Avg. Winding Temperature = 95C
- Winding Hot Spot Temperature = 110C

## High Ambient:

- Max Ambient = 50C
- Max 24 hour Avg. Ambient = 40C
- Must calculate rises not to exceed above absolute temperatures
  - Increase cooling equipment
  - Increase conductor
  - Derate transformer rating

## Effect of Ambient Temperature

# General Requirements

## Effect of Altitude

**Table 1—Dielectric strength correction factor for altitudes greater than 1000 m (3300 ft)**

Altitude m (ft)	Altitude correction factor for dielectric strength
1000 (3300)	1.00
1200 (4000)	0.98
1500 (5000)	0.95
1800 (6000)	0.92
2100 (7000)	0.89
2400 (8000)	0.86
2700 (9000)	0.83
3000 (10 000)	0.80
3600 (12 000)	0.75
4200 (14 000)	0.70
4500 (15 000)	0.67

NOTE—An altitude of 4500 m (15 000 ft) is considered a maximum for transformers conforming to this standard.

C57.12.00 Table 1

**Table E.2—Rated kVA correction factors for altitudes greater than 1000 m (3300 ft)**

Types of cooling	Derating factor% per 100m (330 ft)
Liquid-immersed air-cooled	0.4
Liquid-immersed water-cooled	0.0
Liquid-immersed forced-air-cooled	0.5
Liquid-immersed forced-liquid-cooled with liquid-to-air cooler	0.5
Liquid-immersed forced-liquid-cooled with liquid-to-water-cooler	0.0

C57.91 Table E.2

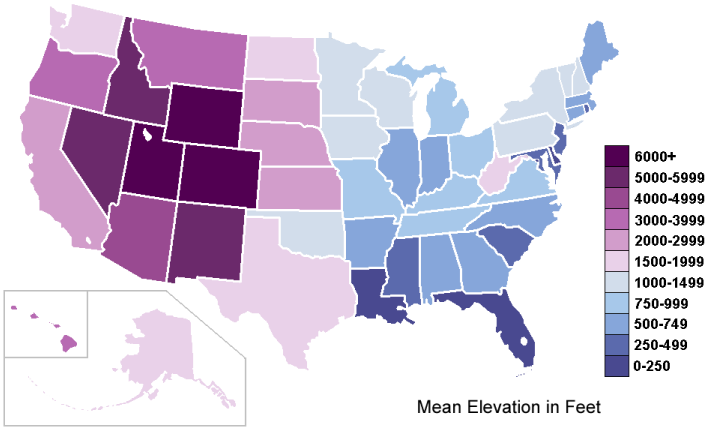



# General Requirements

Retrofit units : (Replacement Transformers , Transformers with Site restrictions

Documents Required :

- Outline of existing unit
- Nameplate of Existing unit
- Foundation dimension and weight limitation
- Site photos
- Information on accessories location (segment)
- Drawing of existing bus duct
- Containment pit and firewall details
- Units with Paralleling Requirements
  - Nameplate of existing unit
  - Test report of existing unit

# General Requirements

## Impedance Consequences

- Standard Impedances are tabulated in C57.12.10-2010 Section 4.6.1
- Standard Impedances are classified by HV BIL and whether or not the unit has an LTC
- Standard Impedances are tabulated for the self-cooled (ONAN) rating

Low Impedance	High Impedance
Increased Secondary Fault Currents	Reduced Secondary Fault Currents
Higher Short Circuit Forces	Potential Voltage Regulation Issues
Higher Interrupting Capacity for Secondary Equipment	Lower Short Circuit Forces
Improved Voltage Regulation	Lower Interrupting Capacity for Secondary Equipment
Lower Leakage Flux, Stray Losses, Winding Losses Higher Core Losses	Higher Leakage Flux, Stray Losses, Winding Losses Lower Core Losses

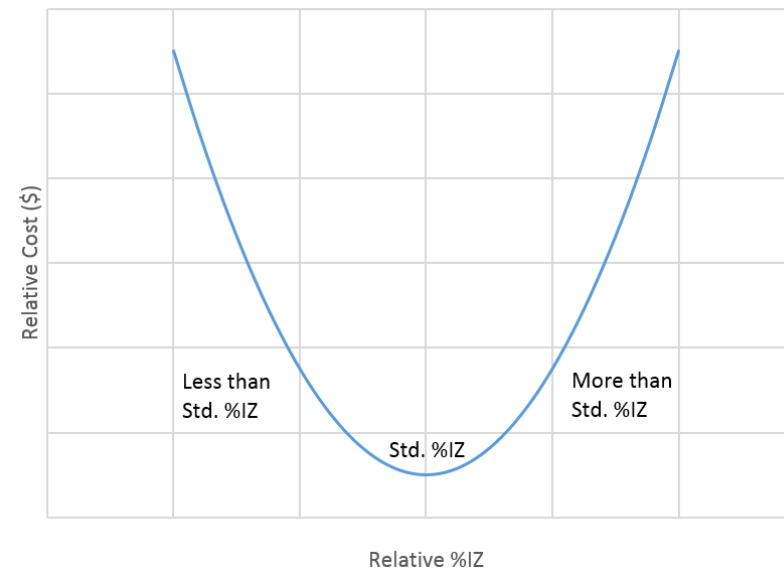

# General Requirements - Impedance

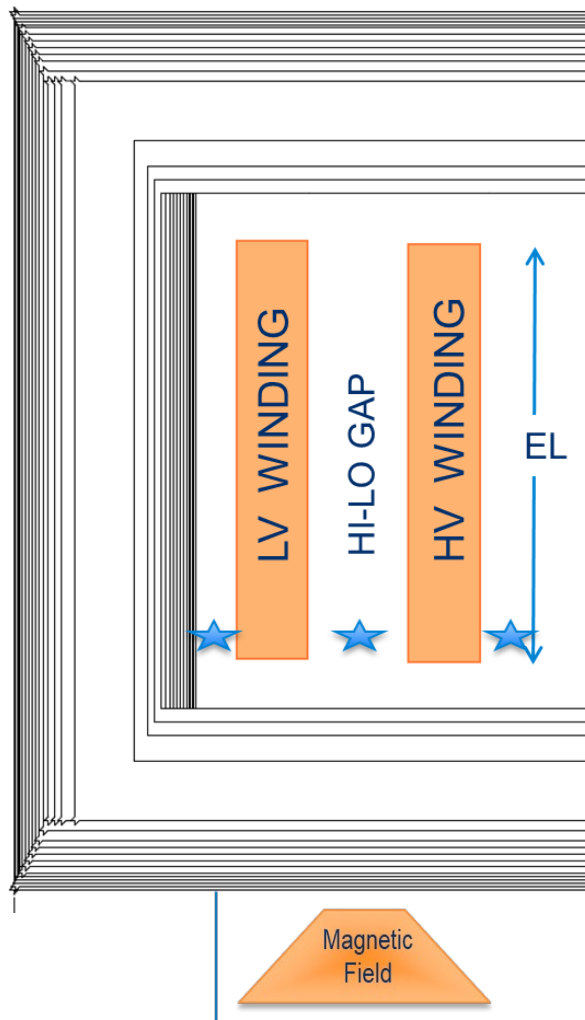

$$\%IX = \frac{1}{(V/N)^2} * \left[ \frac{\frac{1}{3}LV_{BLD} + Hilo + \frac{1}{3}HV_{BLD}}{EL} \right]$$

To Increase the Impedance then:

- Shorten EL
- Increase Hilo or LV/HV Radial Builds
- Increase Turns

★ These Gaps are Prime Real Estate  
Optimize by Reducing the Gaps

# General Requirements

## State the Insulation Level

- Transformer Voltage Class (Class I or Class II)
  - Class II are all transformers with HV  $\geq$  115kV and 3ph units 69kV and 15MVA
- Basic Lightning Impulse Insulation Level (BIL)

## State the Sound Level

- NEMA TR-1
- Low Sound
- Loaded Sound

## State the Loss Evaluation and Loss Penalty

- No Load Losses: \$/kW (typical \$4000/kW)
- Load Losses: \$/kW (typical \$2000/kW)
- Auxiliary Losses: \$/kW (typical \$1200/kW)

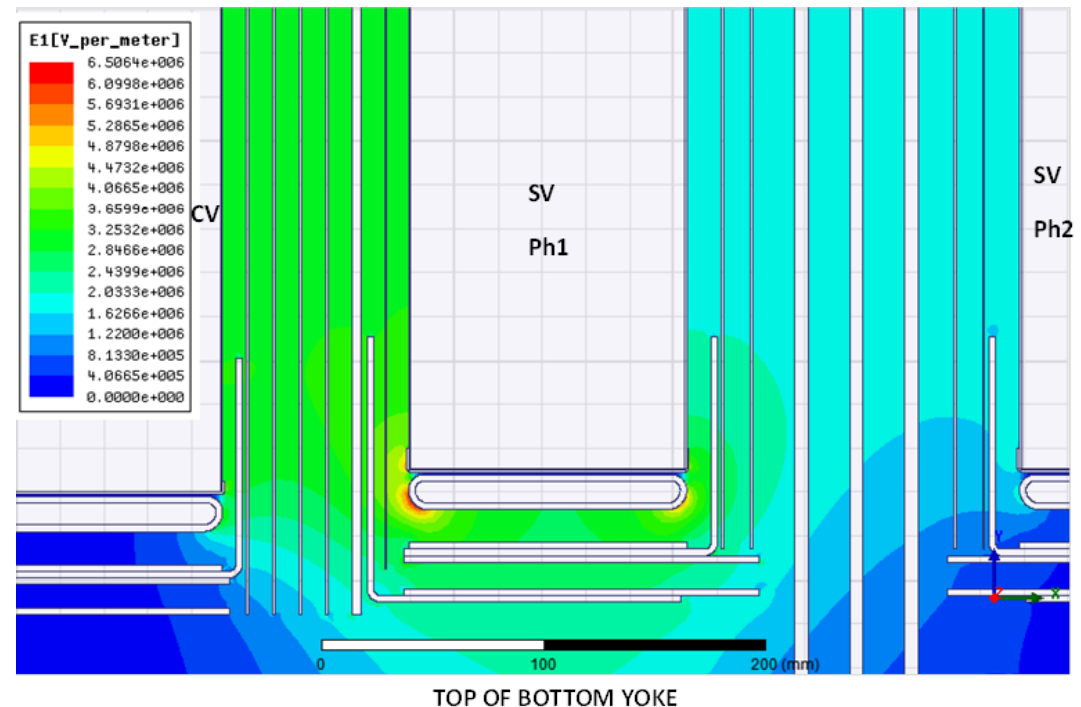

# General Requirements

Year	\$/kW - NL	\$/kW - LL
1989	2890	1180
1990	3280	1560
1991	3170	1370
1992	3000	1440
1993	3250	1550
1994	3070	1470
1995	3340	1920
1996	3078	1626
1997	3225	1587
1998	3140	1590
1999	2113	1063
2000	2245	1251
2001	2190	1243
2002	2245	1153
2003	2360	1194
2004	2492	1325
2005	2659	1388
2006	2810	1377
2007	3025	1490
2008	3162	1571
2009	3792	1860
2010	3863	1852
2011	3752	1957

Year	\$/kW - NL	\$/kW - LL
2012	4408	2540
2013	4073	1930
2014	4215	1907
2015	4349	1880
2016	4467	1906
2017	4340	2240
2018	4270	2200
2019	4370	2250
2020	4390	2287
2021	4377	2256
2022	4500	2400

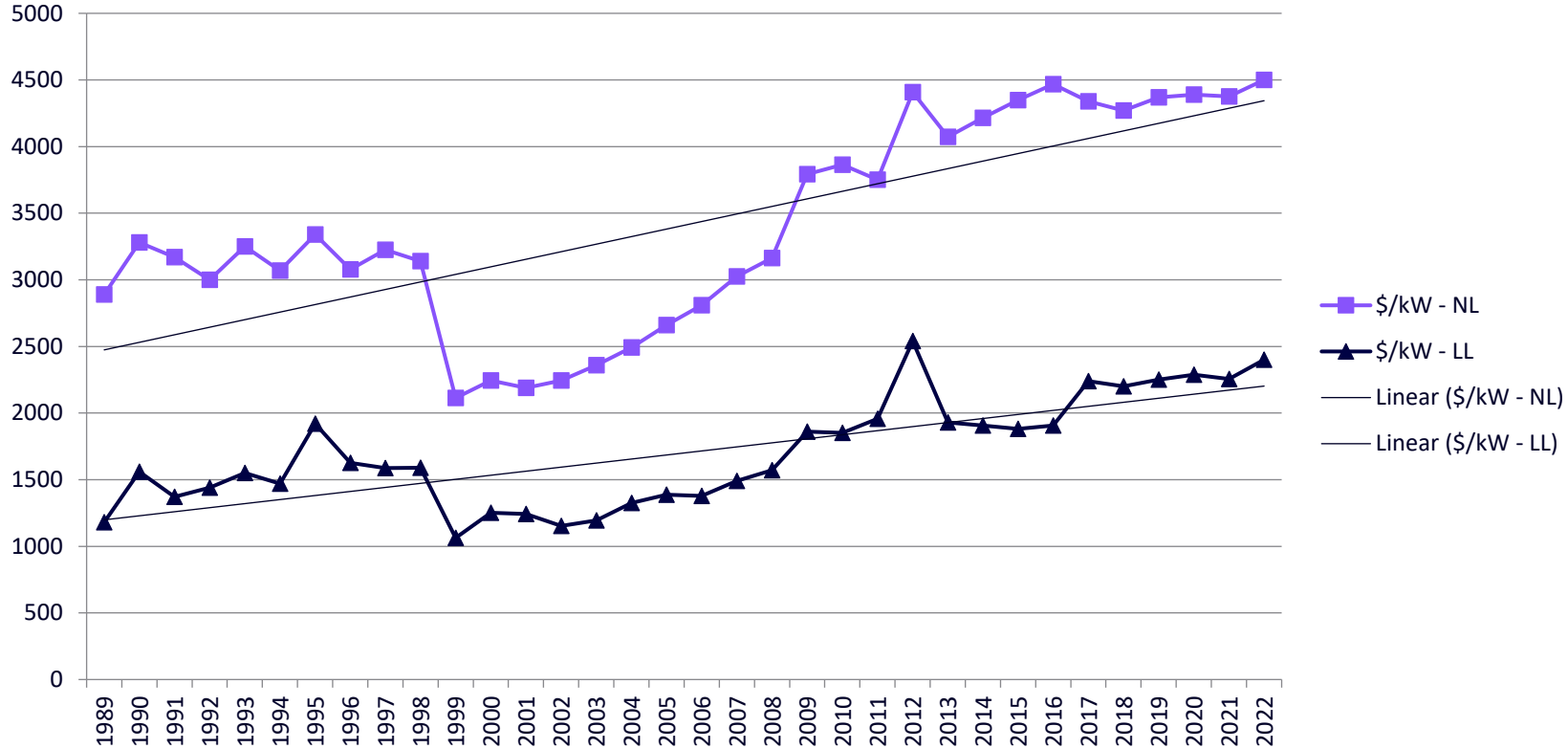

# General Requiriements

## Guides for Loss Evaluation

### **Distribution Transformers**

- “A Method for Economic Evaluation of Distribution Transformers” Report of the EEI Task Force on Distribution Transformer Evaluation” April 1981
- “Guide for Evaluation of Distribution Transformers - Parts I & II” GE Industrial & Power Systems and References contained therein

### **Power Transformers**

- ANSI/IEEE C57.120 “IEEE Loss Evaluation Guide for Power Transformers and Reactors” and references in its bibliography

# General Requirements

## Transformers with Series Parallel Application

### Multiple Voltage Windings

- Future system upgrades
- System spare for different voltages
- Even multiple - cost effective design
- Uneven multiple - can increase design complexity

Even =



Uneven =

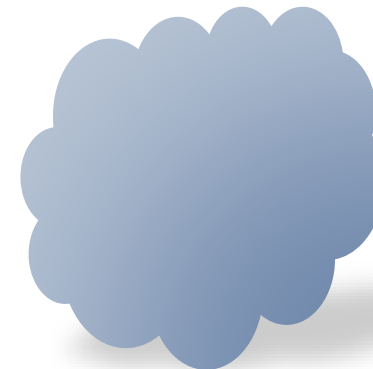

# General Requirements

## Even Ratio Series/Multiple Transformers

- Favorable Ampere-Turn Balance
- Minimum Short-Circuit Forces
- Minimum Stray Loss Problems
- Specify BIL for each connection
- Series/Multiple Switch is often available



2 : 1  
Ex: 138x69

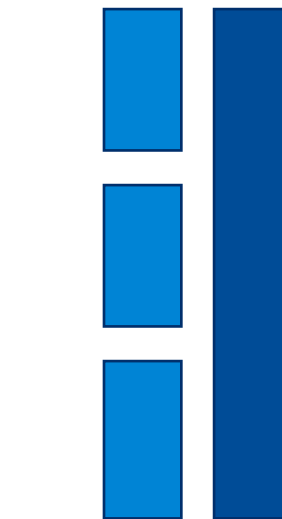

3 : 1  
Ex: 13.09x4.36



4 : 1  
Ex: 138x34.5



# General Requirements

## Uneven Ratio Series/Multiple Transformers

- Unfavorable Ampere-Turn Balance
- Large Short-Circuit Forces
- Potential Stray Loss Problems
- Specify BIL for each connection. Specify Shipping Connection.
- Terminal Board Often Required

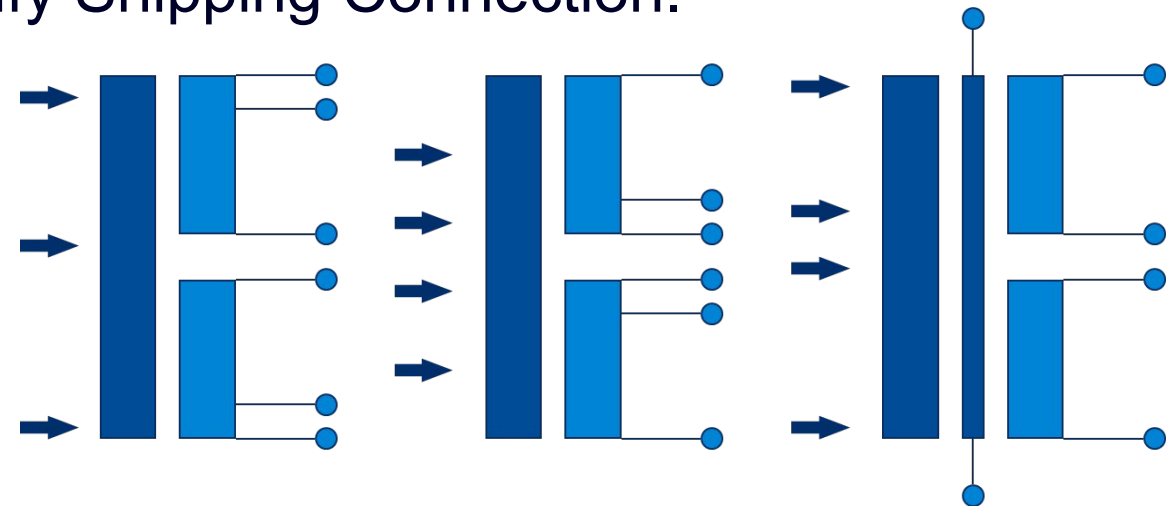

Examples: 161x115, 161x69, 115x69, 26.4x12.47



# Core Design Requirements

# Core Design Requirements

## Core Flux Density Limits

- Over-excitation capability
- Hard limits at various levels of excitation (Ex. 1.93T at 110% Voltage)

## Core Hotspot Temperature Limits

- C57.91-2011 Table 9 States 140C (with 40C ambient)
- Surface Limit and Internal Limit
- Outer-Packet Temperature

## Core Cooling Ducts

- Quantity, Material, Insulating

## Core Construction

- Number of Legs
- Material (Laser Scribed, thickness)
- Shape of legs and yokes
- Method of grounding

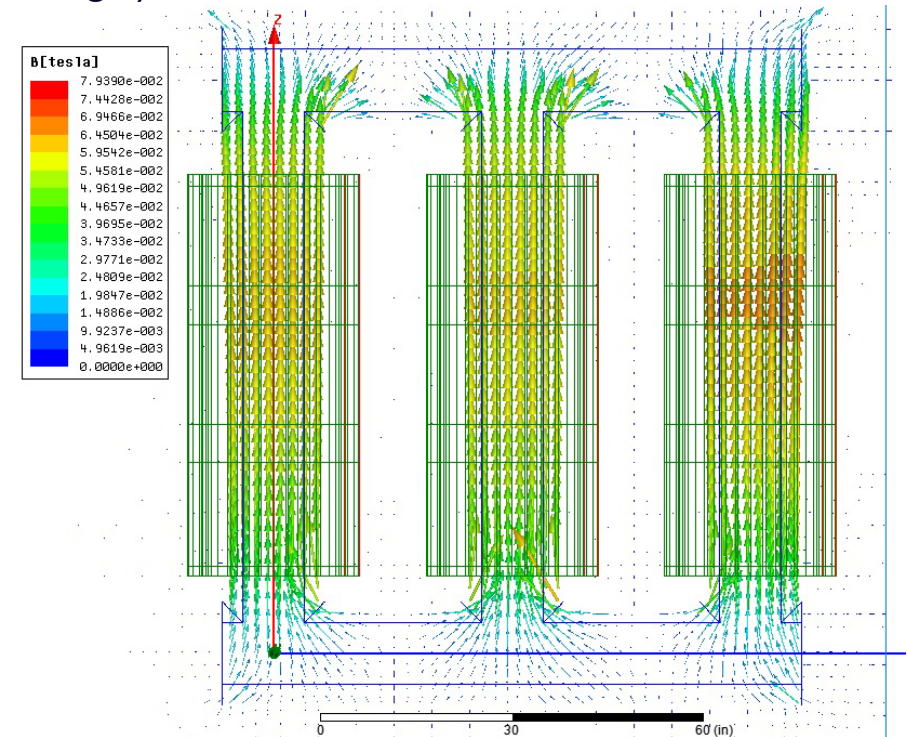

# Core Design Requirements

## Core Clamping Design

- Grounding Method
- Shipping and Seismic Forces
- Locking Method to Tank
- Temperature Limits
- Methods for Stray Loss Reduction
- Shunts (construction or flux density limits)
- Allowable Deflection of Pressure Plates and Clamp
- Insulation Requirements (pressure plates, duct material etc)
- Fixed Clamp, Adjustable Clamp, Independent Phase Clamping

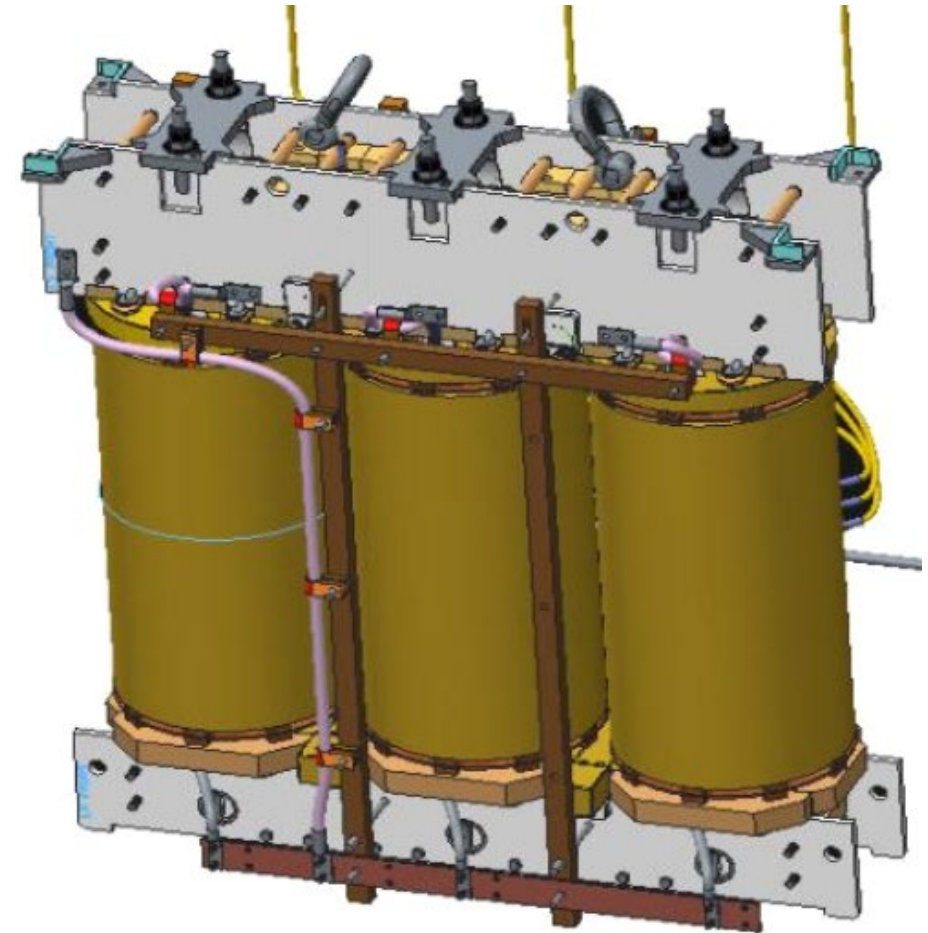



# Winding Design Requirements

# Winding Design Requirements

## Winding Types

- Disc, Helix, Layer, Multi-Layer

## Conductor Type

- Foil Sheet, Magwire, CTC

## Conductor Insulation

- Specific Paper Type
- Paperless or Enamel

## Minimum Paper Build

- Coverage and Overlap

## Duct Structure

- Winding to Winding
- Layer to Layer
- Disc to Disc



# Winding Design Requirements

## Disc Winding

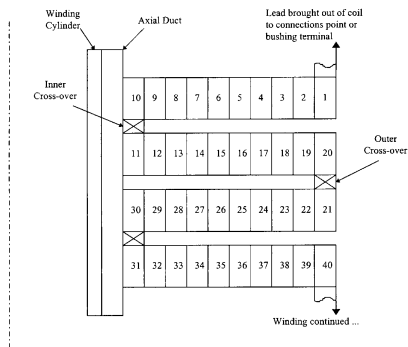

- Ideal for HV Wdg
- More Turns
- Less CSA
- Few Conductor per Turn
- Multiple Turns per Disc
- Typical min 160 Turns
- Keyspacers Used

## Helical Winding

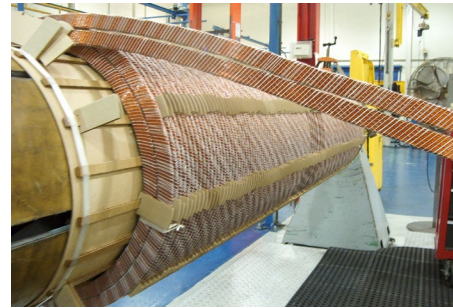

- Ideal for LV & TV Wdg
- Less Turns
- More CSA
- Many Conductor per Turn
- One Turn per Disc
- Typical max 160 Turns
- Keyspacers Used

## Layer Winding

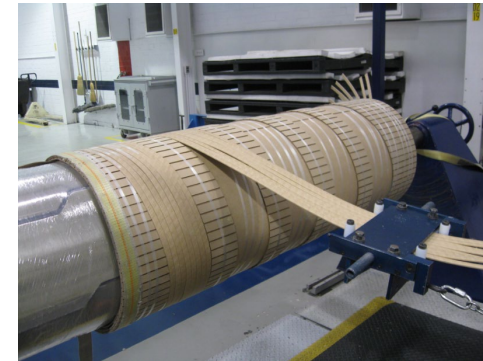

- Ideal for LV & TV Wdg
- Less Turns
- More CSA
- Many Conductor per Turn
- One Turn per Disc
- Typical max 200 Turns
- No Keyspacers Used

# Winding Design Requirements

- Conductor Hardness and Tolerance
- Cooling Method
  - Internal Ducts – Compressible
  - Oil Guide Design
  - Directed or non-directed
- Insulation Supplier
- Insulation Dryness (< 0.5% at shipment)
- Insulation Shrinkage
- Insulation Density
- Coil Sizing Tolerances and Sizing Pressure
- Overbuild Tolerances







# Short Circuit Withstand Requirements

# Short Circuit Withstand Requirements

- Pre-fault Conditions
- System Impedance
- Types of Faults to Consider
- Faults Possible on TV windings
- Failure Modes to Consider
- Margins from Critical Failure Point
- Specific Short Circuit Programs (Andersen)
- Offset of Winding Centers used in Calculations
- Possibly Specify CTC for inner windings



# Short Circuit Withstand Requirements

- Short Circuit Current shall only be limited by the transformer impedance / Windings shall be designed for infinite bus condition (no system impedance).
- Any pre-fault operating voltage greater than 1.0 per unit rated voltage
- Any customer specified asymmetrical peak factor (Ex: 2.762)
- Any customer specified minimum offset of the winding's electrical centers
- Any customer specified buckling limits
  - Example: Stress must be less than 35% of yield strength for Magwire
- Customer specifies CTC for all windings subjected to compressive forces (all inner windings)
- Fault Duration longer than 2 seconds
- Special Fault Duty (C57.12.00-2015 Section 7.1.5.5)



# Dielectric Withstand Requirements

# Dielectric Withstand Requirements

- Front-of Wave Test (Stress on Line end)
- Switching Surge Test (Stress Phase to Phase)
- Conversion Factors for all Tests
- Specify Margin
  - Local Stress
  - Oil Duct Stress between Windings
  - How to calculate margin
  - Gas Saturated or Degassed Oil
  - Insulated or un-insulated electrodes
- Requirements for Field Plots
- Material Requirements for pressure plates and board work

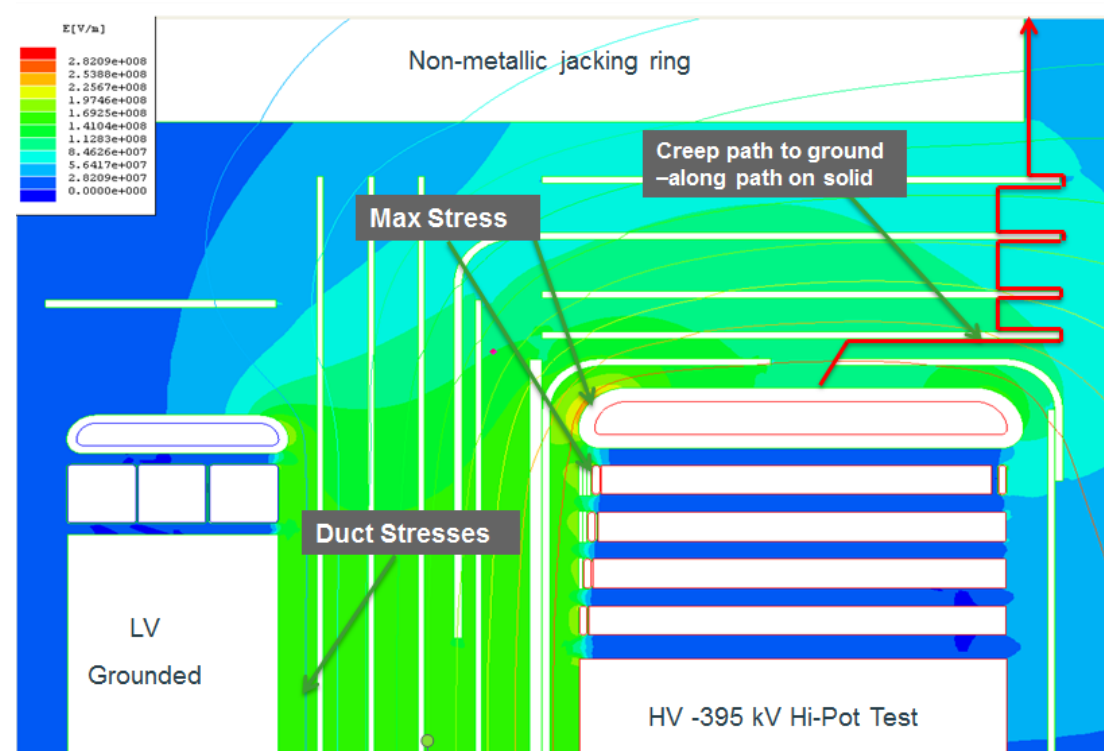

# Dielectric Withstand Requirements

- Determine All Service and Test Voltages
- Equate All to AC Equivalent Voltage (Eav)
- Find Max Eav
- Calculate Stress in Oil Gaps\*
- Calculate Strength of Oil Gaps\*
- Check Local Stress

\*Alternatively Can Use Average Oil Stress Method for Approximation of Required Gap

Example:

$$\begin{aligned}
 Hilo_{Min} &= \frac{Eav}{Edim} + \frac{ins}{2} \\
 &= \frac{100kv}{5kv/mm} + \frac{3mm}{2} \\
 &= 21.5mm
 \end{aligned}$$

45-13.2 kV Dyn1 Transformer					
Dielectric Test	Test Voltage	Unit	Eav Factor	Eav	Comment
Full Wave Impulse	250	kV	2.5	100	HV
Applied Test (Hipot)	95	kV	1	95	HV
Induced Test (1 hour)	42	kV	0.85	49	HV Line to Ground
Induced Test (1 hour)	73	kV	0.85	86	HV Line to Line
Switching Surge	208	kV	2.1	99	HV

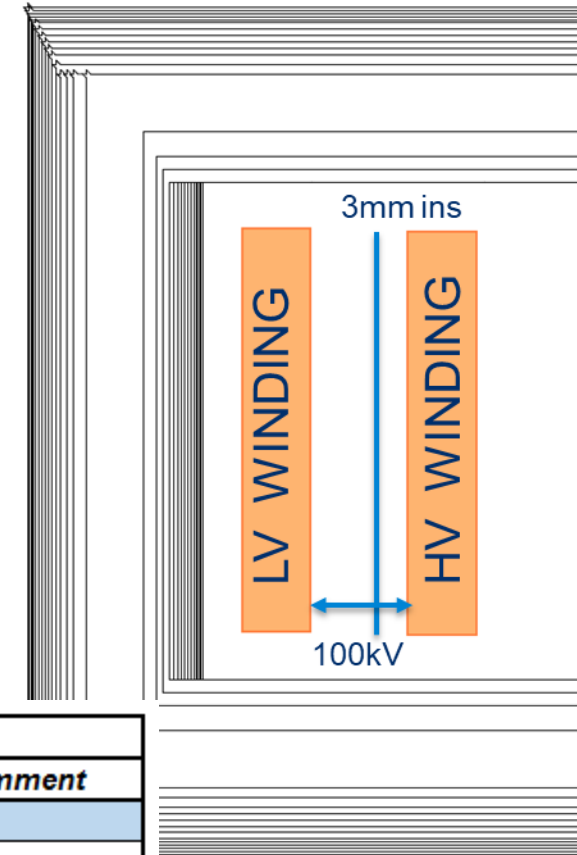



# Thermal Requirements

# Thermal Requirements

- Load Capability of Bushings and Tap Changers
- Temperature Rise of Lead Cables
- Temperature Rise of Winding Exits
- Temperature Rise of Non-Current Carrying Metallic Components
- Transformer to be Limited by the Winding Hotspot
- Winding and Oil Exponents and Time Constants
- Information Required for Specifying Overload (C57.91-2011 Section 9.7)
  - Load Cycle or Stepped Loading Profile
  - Ambient Profile
  - Temperature Limits
  - Top Oil
  - Hotspot
  - % Loss of Life

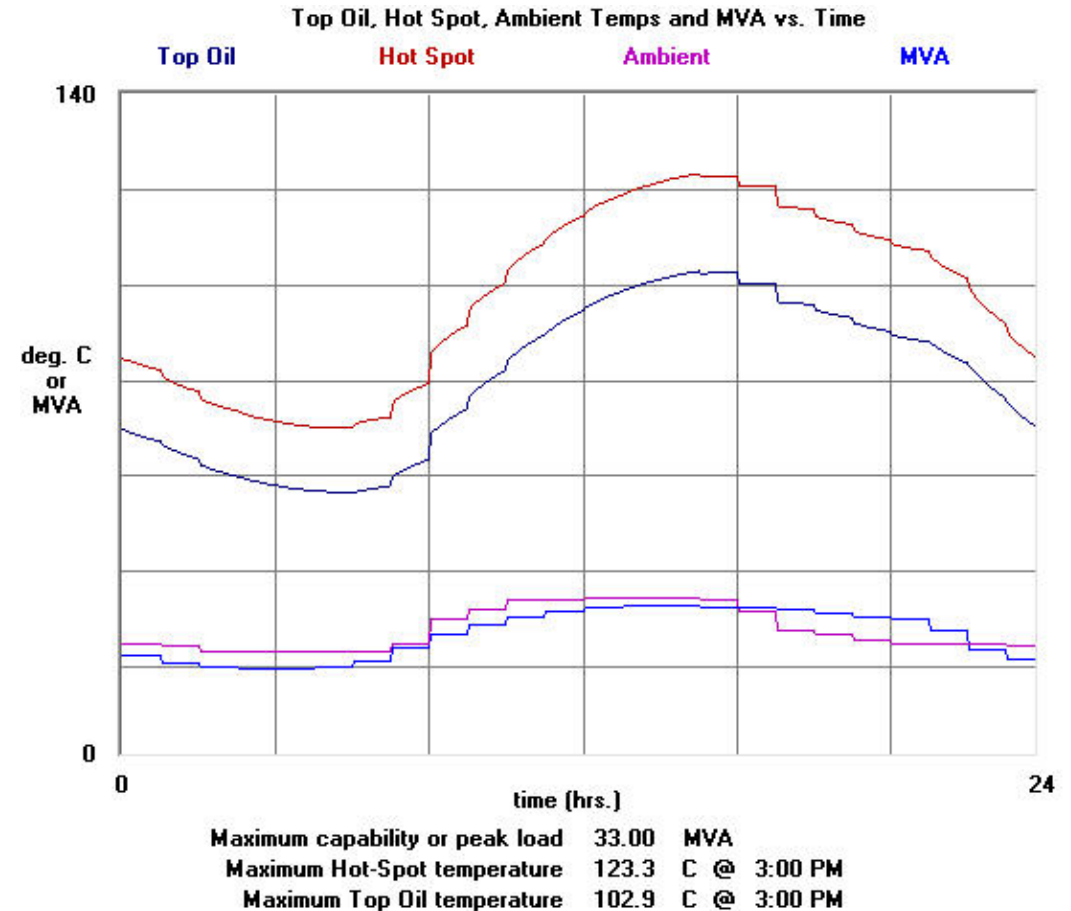





# Accessories and Monitoring Requirements

# Accessories and Monitoring Requirements

- Temperature Equipment
  - LTI
  - WTI
  - ETM
- Liquid Level
- Tank Pressure
  - PRD, SPR
- Gas Generation
  - Gas Detection Relay
  - Buchholz Relay
- Monitoring
  - Bushing and pD
  - DGA
  - Fiber-Optic



# Accessories and Monitoring Requirements

- DETC
  - +/- 2 Steps at 2.5%
  - Current Ratings
  - Contact Withstand
  - Contact Plating
- LTC
  - +/- 16 Steps at 5/8%
  - Current Ratings
  - Contact Withstand
  - Maintenance
  - Vacuum or Arching in Oil
  - Resistive or Reactive
  - Location – HV or LV
  - CFVV or VFVV
  - Spare Parts





# Testing Requirements

# Testing Requirements

## ANSI/IEEE Requirements

- Routine – Every Unit
- Design – 1st of New Designs
- Other - User Specified
  
- C57.12.00 Defines Standard Tests
  
- C57.12.90 State How Tests are to be Performed



# Testing Requirements

## Items to Specify

- Establish Acceptance Criteria
- Sequence of Tests
- Timing of Tests
- Temperature Rise Test
- Sound Test (No Load or Loaded)
- FOW, Switching Surge
- Single Phase Excitation

## Temperature Rise Test

- Time / energy consuming
- Occupies test floor and disrupts normal production cycle
- User specific non-standard
- Request as adders
- Overload, M/N Exponents. IR Scans



waukesha  
a proleco company

# Questions



## **Contact**

Manu Sandhar  
Electrical Design Engineer

Prolec-GE Waukesha, Inc.  
Waukesha, WI  
manpreet.sandhar@prolec.energy  
T 262-446-8499  
M 262-606-7196

**[www.waukeshatransformers.com](http://www.waukeshatransformers.com)**