

Transformer Components 35 kV Class 900 Amp RMS Deadbreak Bushing

GENERAL

Designed and manufactured in accordance with the requirements of IEEE Std. 386™-2016, standard for separable insulated connector systems. Deadbreak bushing, 35 kV 900 A bushing, will adopt all 900 Amp RMS separable connectors manufactured according to IEEE Std. 386™-2016.

This bushing is made of epoxy polymer with built-in stainless ground shield, electrical grounding is automatically completed by direct connection between the bushing clamp and the three ground clips which were already connected to the built-in ground shield in factory. Epoxy bushing is designed for sidewall mounting in transformers, switches and other apparatus filled with mineral transformer oil, or an approved equivalent. All separable connector systems on the market can be used with this bushing.

INSTALLATION

Required no special tools the bushing is mounted through the transformer or switchgear sidewall by externally clamping the stainless clamp, furnished with the bushing, refer to the installation manual furnished with the bushing.

PRODUCTION TESTS

Tests are conducted according to IEEE Std. 386™-2016:

- AC 60 Hz 1 minute withstand: 70 kV
- Minimum partial discharge extinction level: 26 kV [standard]

Tests conducted in accordance with Celeco® requirements:

- Physical inspection
- Periodic dissection
- Periodic fluoroscopic analysis
- Periodic impulse withstand



TECHNICAL DATA

TABLE 1 - Voltage and Current Ratings and Characteristics - IEEE Std. 386™-2016

Voltage and current ratings	35 kV Class
Operating voltage	
Maximum phase-to-phase	36.6 kV
Maximum phase-to-ground	21.1 kV
Withstand voltage	
AC: 50 Hz or 60 Hz, 60 sec	70 kV
DC: 15 minutes	114 kV
Impulse voltage withstand	
BIL and full wave crest	200 kV
Minimum partial discharge extinction level < 3 pC	26 kV
Continuous current rating	900 Amp
Symmetrical momentary current	10 kA sym. for 10 cycles (0.17 s)
Short time	25,000 Amp RMS symmetrical for 0.17 s
	10,000 Amp RMS symmetrical for 3.0 s

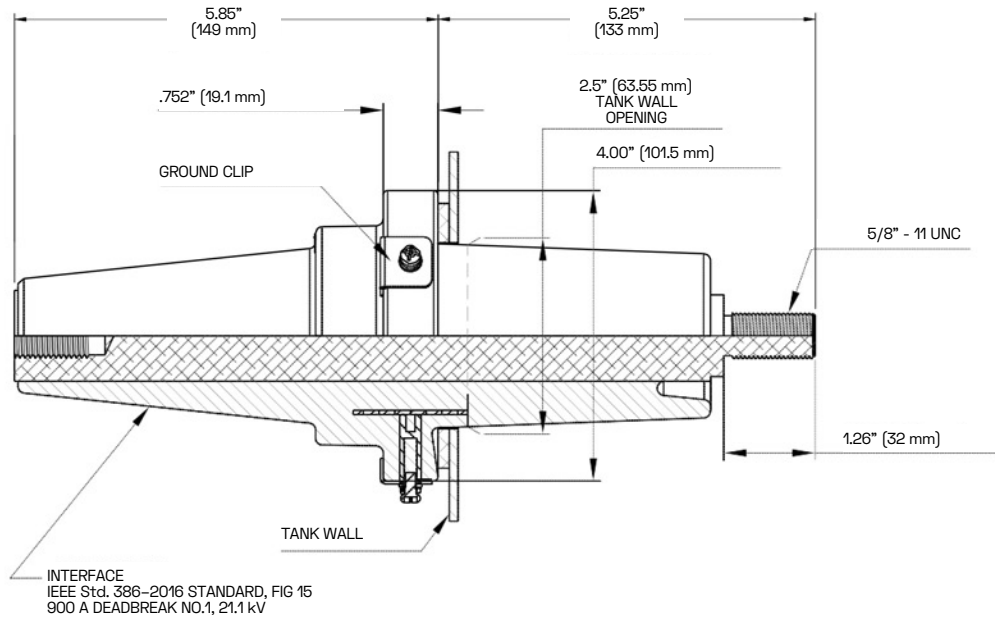

35 kV 900 A BUSHING

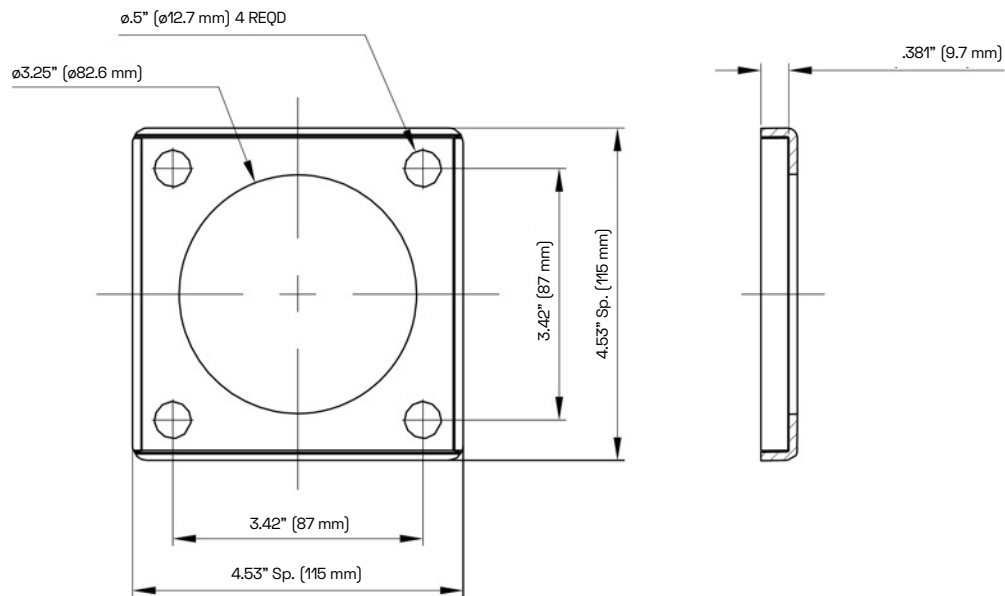

STAINLESS STEEL CLAMP

Typical accessories supplied with each deadbreak bushing:

- Shipping cap (not for energized operation) 1
- Stainless steel clamp 1
- Oil resistant gasket 1
- Installation instruction sheet 1

Note: If you request an aluminum threaded stud for EOB392, please contact Celeco representative.