

Wildlife Guards Arrester Bracket Self Extinguish Guard

GENERAL

Celeco[®] arrester bracket self extinguish guard is manufactured with flame retardant material, protects the grounded bolt to prevent outages caused by wildlife contact to lightning arresters on overhead distribution transformers. This prevention is achieved by covering the grounded bolt on the arrester bracket and thus lowering the risk of flashover of the arrester.

FEATURES

Our arrester bracket self extinguish guard:

- Prevents harm to wildlife
- Fits all common brands of polymer arresters
- Easy installation and retrofit
- Innovative and superior snap fit for installation, no taping is necessary to stay securely located in place
- Robust and rigid material
- Enhanced polypropylene resin for long service life
- Achieves a V0 flammability classification, the highest rating for UL94 test standard
- Flame retardant material
- Passed the IEEE standard 1656-2010™ tests
 - Hi-pot (exceeded 24 kV)
 - Cold temperature
 - Retention
 - Ultraviolet aging

INSTALLATION

1. Position the guard between bracket's first and second sheds then clip one snap below bracket's body.
2. Twist guard until the other snap click below bracket body.

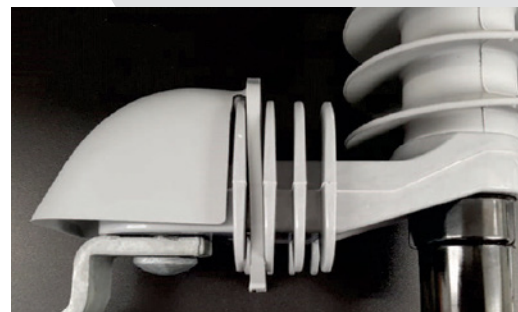

3. Press cover until is secured, both snaps must wrap around bracket.
4. To remove guard, twist cover and push up to unclamp the snaps.

INSTALLATION

Product name	Part no.	Pack size
Arrester bracket self extinguish guard	B2045	200

Figure 1: Arrester bracket self extinguish guard dimensions.

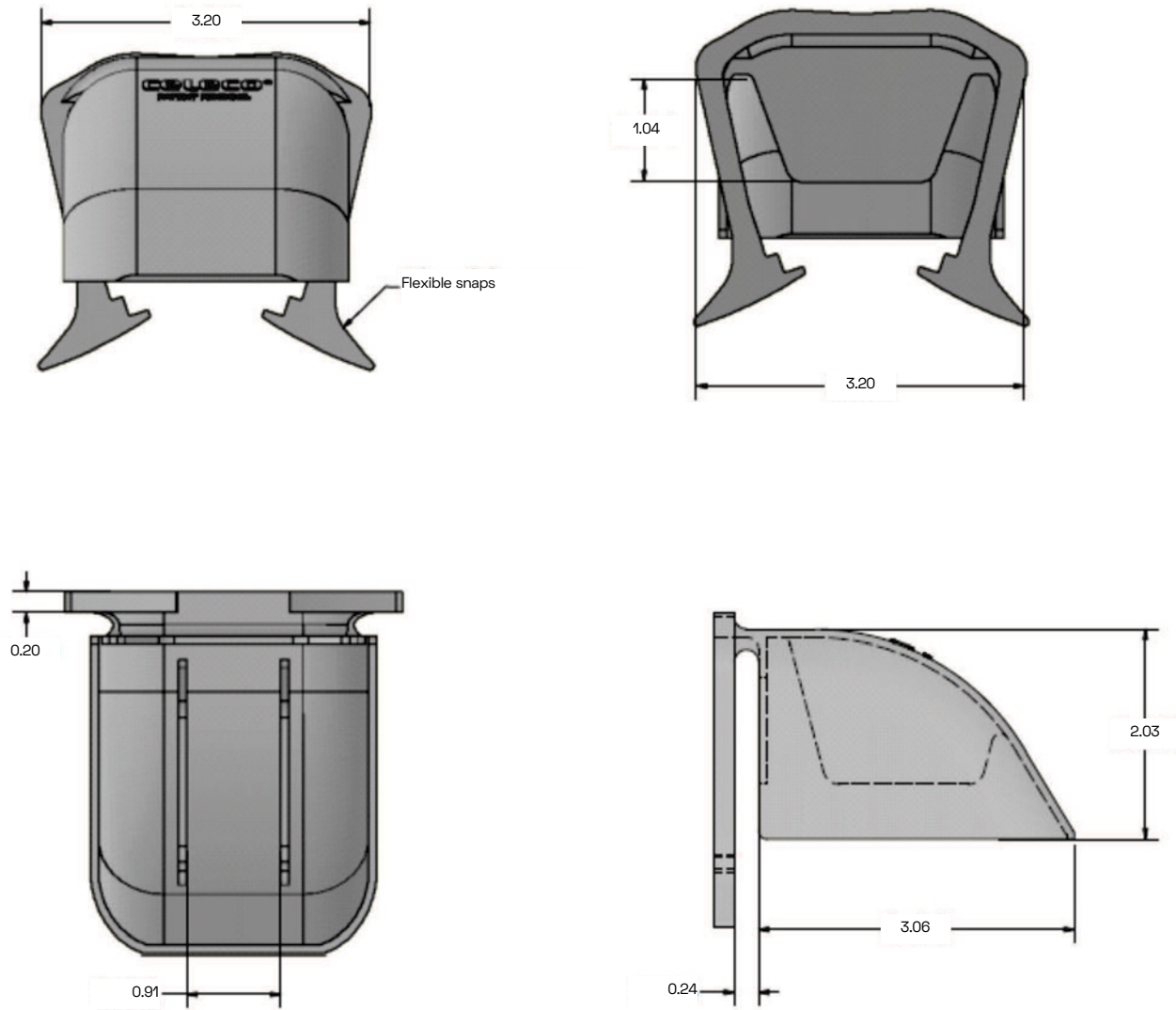

NOTES:

WILDLIFE GUARD

- MATERIAL THERMOPLASTIC
- COPOLYMER POLYPROPYLENE
- UV STABILIZED
- FLAME RATE VO UL 94
- COLOR GRAY #70
- TOLERANCES ± 0.050
- FLAME RETARDANT MATERIAL